

Satellite Pro[®] 4600 Series User's Guide

Tips for viewing PDFs:

- ❖ To use bookmarks, click the Bookmarks tab, then click the plus sign (+) next to the bookmark icon to display topics in that chapter. Click the minus (-) sign to collapse again.
- ❖ To use thumbnails, click the Thumbnails tab, and double click on the page number you want to view. (The page will appear on the right side of your screen.)
- ❖ To print, specify a range of pages in the Acrobat Print dialog box, or specify noncontiguous pages or a particular page before opening the dialog box. Click the Print button or choose File > Print.

For more information, select Help > Reader Guide from the Adobe Acrobat window.

If You Need Assistance:



- ❖ VirtualTech[™] e-support tool

Double-click on the desktop icon or visit the website:

<http://virtualtech.answersteam.com>

- ❖ InTouchsm Center

Calling within the United States (800) 457-7777

Calling from outside the United States (949) 859-4273

For more information, see [Chapter 9](#) on page 177 of this guide.

Compact Disk-Read/Write

The computer system you purchased may include a Compact Disk-Read/Write (CD-RW), one of the most advanced storage technologies available. As with any new technology, you must read and follow all set-up and usage instructions in the applicable user guides and/or manuals enclosed. If you fail to do so, this product may not function properly and you may lose data or suffer other damage. TOSHIBA AMERICA INFORMATION SYSTEMS (“TOSHIBA”), ITS AFFILIATES AND SUPPLIERS DO NOT WARRANT THAT OPERATION OF THE PRODUCT WILL BE UNINTERRUPTED OR ERROR FREE. YOU AGREE THAT TOSHIBA, ITS AFFILIATES AND SUPPLIERS SHALL HAVE NO RESPONSIBILITY FOR DAMAGE TO OR LOSS OF ANY BUSINESS, PROFITS, PROGRAMS, DATA OR REMOVABLE STORAGE MEDIA ARISING OUT OF OR RESULTING FROM THE USE OF THE PRODUCT, EVEN IF ADVISED OF THE POSSIBILITY THEREOF.

Protection of Stored Data

For your important data, please make periodic back-up copies of all the data stored on the hard disk or other storage devices as a precaution against possible failures, alteration, or loss of the data. IF YOUR DATA IS ALTERED OR LOST DUE TO ANY TROUBLE, FAILURE OR MALFUNCTION OF THE HARD DISK DRIVE OR OTHER STORAGE DEVICES AND THE DATA CANNOT BE RECOVERED, TOSHIBA SHALL NOT BE LIABLE FOR ANY DAMAGE OR LOSS OF DATA, OR ANY OTHER DAMAGE RESULTING THEREFROM. WHEN COPYING OR TRANSFERRING YOUR DATA, PLEASE BE SURE TO CONFIRM WHETHER THE DATA HAS BEEN SUCCESSFULLY COPIED OR TRANSFERRED. TOSHIBA DISCLAIMS ANY LIABILITY FOR THE FAILURE TO COPY OR TRANSFER THE DATA CORRECTLY.

Critical Applications

The computer you have purchased is not designed for any “critical applications.” “Critical applications” means life support systems, medical applications, connections to implanted medical devices, commercial transportation, nuclear facilities or systems or any other applications where product failure could lead to injury to persons or loss of life or catastrophic property damage.

ACCORDINGLY, TOSHIBA, ITS AFFILIATES AND SUPPLIERS DISCLAIM ANY AND ALL LIABILITY ARISING OUT OF THE USE OF THE COMPUTER PRODUCTS IN ANY CRITICAL APPLICATIONS. IF YOU USE THE COMPUTER PRODUCTS IN A CRITICAL APPLICATION, YOU, AND NOT TOSHIBA, ASSUME FULL RESPONSIBILITY FOR SUCH USE.

Models: Satellite Pro 4600 Series

FCC Notice “Declaration of Conformity Information”

This equipment has been tested and found to comply with the limits for a Class B digital device, pursuant to Part 15 of the FCC rules. These limits are designed to provide reasonable protection against harmful interference in a residential installation.

This equipment generates, uses and can radiate radio frequency energy and, if not installed and used in accordance with the instructions, it may cause harmful interference to radio communications. However, there is no guarantee that interference will not occur in a particular installation. If this equipment does cause harmful interference to radio or television reception, which can be determined by turning the equipment off and on, the user is encouraged to try to correct the interference by one or more of the following measures:

- ❖ Reorient or relocate the receiving antenna.
- ❖ Increase the separation between the equipment and receiver.
- ❖ Connect the equipment to an outlet on a circuit different from that to which the receiver is connected.
- ❖ Consult the dealer or an experienced radio/TV technician for help.



NOTE: Only peripherals complying with the FCC Class B limits may be attached to this computer. Operation with non-compliant peripherals or peripherals not recommended by Toshiba is likely to result in interference to radio and TV reception. Shielded cables must be used between the external devices and the computer's serial port, parallel port, video-out port, television jack, USB port, PS/2™ port, network port, and microphone jack. Changes or modifications made to this equipment not expressly approved by Toshiba or parties authorized by Toshiba could void the user's authority to operate the equipment.

This device complies with Part 15 of the FCC Rules. Operation is subject to the following two conditions:

- ❖ This device may not cause harmful interference.
- ❖ This device must accept any interference received, including interference that may cause undesired operation.

Contact:

Toshiba America Information Systems, Inc.
9740 Irvine Blvd.
Irvine, CA 92618-1697
(949) 583-3000

Industry Canada Requirement

This Class B digital apparatus complies with Canadian ICES-003.

Cet appareil numérique de la classe B est conformé à la norme NMB-003 du Canada.

FCC Requirements

The following information is pursuant to FCC CFR 47, Part 68 and refers to internal modems.

Installation

When you are ready to install or use the modem, call your local telephone company and give them the following information:

- ❖ The telephone number of the line to which you will connect the modem
- ❖ The FCC registration number of the modem
- ❖ The ringer equivalence number (REN) of the modem, which is 0.6B

The modem connects to the telephone line by means of a standard jack called the USOC RJ11C.

Type of service

Your modem is designed to be used on standard-device telephone lines. Connection to telephone company-provided coin service (central office implemented systems) is prohibited. Connection to party line service is subject to State tariffs. If you have any questions about your telephone line, such as how many pieces of equipment you can connect to it, your telephone company will provide this information upon request.

6

Telephone Company Procedures

The goal of the telephone company is to provide you with the best service it can. In order to do this, it may occasionally be necessary for them to make changes in their equipment, operations or procedures. If these changes might affect your service or the operation of your equipment, the telephone company will give you notice, in writing, to allow you to make any changes necessary to maintain uninterrupted service.

If Problems Arise

If any of your telephone equipment is not operating properly, you should immediately remove it from your telephone line, as it may cause harm to the telephone network. If the telephone company notes a problem, they may temporarily discontinue service. When practical, they will notify you in advance of this disconnection. If advance notice is not feasible, you will be notified as soon as possible. When you are notified, you will be given the opportunity to correct the problem and informed of your right to file a complaint with the FCC. In the event repairs are ever needed on your modem, they should be performed by Toshiba Corporation or an authorized representative of Toshiba Corporation.

Disconnection

If you should ever decide to permanently disconnect your modem from its present line, please call the telephone company and let them know of this change.

Fax Branding

The Telephone Consumer Protection Act of 1991 makes it unlawful to use a computer or other electronic device to send any message via a telephone fax machine unless such message clearly contains in a margin at the top or bottom of each transmitted page or on the first page of the transmission, the date and time it is sent and an identification of the business, other entity or individual sending the message and the telephone number of the sending machine or such business, other entity or individual.

In order to program this information into your fax modem, you should complete the setup for your fax software before sending a message.

Instructions for IC CS-03 certified equipment

- 1 **NOTICE:** The Industry Canada label identifies certified equipment. This certification means that the equipment meets certain telecommunications network protective, operational and safety requirements as prescribed in the appropriate Terminal Equipment Technical Requirements document(s). The Department does not guarantee the equipment will operate to the user's satisfaction.

Before installing this equipment, users should ensure that it is permissible to be connected to the facilities of the local telecommunications company. The equipment must also be installed using an acceptable method of connection. The customer should be aware that compliance with the above conditions may not prevent degradation of service in some situations.

Repairs to certified equipment should be coordinated by a representative designated by the supplier. Any repairs or alterations made by the user to this equipment, or equipment malfunctions, may give the telecommunications company cause to request the user to disconnect the equipment.

Users should ensure for their own protection that the electrical ground connections of the power utility, telephone lines and internal metallic water pipe system, if present, are connected together. This precaution may be particularly important in rural areas.

CAUTION: Users should not attempt to make such connections themselves, but should contact the appropriate electric inspection authority, or electrician, as appropriate.

- 2 The user manual of analog equipment must contain the equipment's Ringer Equivalence Number (REN) and an explanation notice similar to the following:

The Ringer Equivalence Number (REN) of this device is 0.3.

NOTICE: The Ringer Equivalence Number (REN) assigned to each terminal device provides an indication of the maximum number of terminals allowed to be connected to a telephone interface. The termination on an interface may consist of any combination of devices subject only to the requirement that the sum of the Ringer Equivalence Numbers of all the devices does not exceed 5.

- 3 The standard connecting arrangement (telephone jack type) for this equipment is jack type(s): USOC RJ11C.

Wireless Interoperability

The Toshiba Wireless LAN Mini PCI Card products are designed to be interoperable with any wireless LAN product that is based on Direct Sequence Spread Spectrum (DSSS) radio technology, and is compliant to:

- ❖ The IEEE 802.11 Standard on Wireless LANs (Revision B), as defined and approved by the Institute of Electrical and Electronics Engineers.
- ❖ The Wireless Fidelity (Wi-Fi) certification as defined by the WECA Wireless Ethernet Compatibility Alliance.

Wireless LAN and your Health

Wireless LAN products, like other radio devices, emit radio frequency electromagnetic energy. The level of energy emitted by Wireless LAN devices however is far much less than the electromagnetic energy emitted by wireless devices like for example mobile phones. Because Wireless LAN products operate within the guidelines found in radio frequency safety standards and recommendations, Toshiba believes Wireless LAN is safe for use by consumers. These standards and recommendations reflect the consensus of the scientific community and result from deliberations of panels and committees of scientists who continually review and interpret the extensive research literature.

In some situations or environments, the use of Wireless LAN may be restricted by the proprietor of the building or responsible representatives of the organization. These situations may for example include:

- ❖ Using the Wireless LAN equipment on board of airplanes, or
- ❖ In any other environment where the risk of interference to other devices or services is perceived or identified as harmful.

If you are uncertain of the policy that applies on the use of wireless devices in a specific organization or environment (e.g., airports), you are encouraged to ask for authorization to use the Wireless LAN device prior to turning on the equipment.

Regulatory Information

The Toshiba Wireless LAN Mini PCI Card must be installed and used in strict accordance with the manufacturer's instructions as described in the user documentation that comes with the product. This device complies with the following radio frequency and safety standards.

Canada – Industry Canada (IC)

This device complies with RSS 210 of Industry Canada.

Operation is subject to the following two conditions: (1) this device may not cause interference, and (2) this device must accept any interference, including interference that may cause undesired operation of this device.

USA-Federal Communications Commission (FCC)

This device complies with Part 15 of FCC Rules. Operation of the devices in a Wireless LAN System is subject to the following two conditions:

- ❖ This device may not cause harmful interference.
- ❖ This device must accept any interference that may cause undesired operation.

Caution: Exposure to Radio Frequency Radiation

The radiated output power of the Toshiba Wireless LAN Mini PCI Card is far below the FCC radio frequency exposure limits. Nevertheless, the Toshiba Wireless LAN Mini PCI Card shall be used in such a manner that the potential for human contact during normal operation is minimized. When using this device in combination with Wireless LAN Outdoor Antenna products, a certain separation distance between antenna and nearby persons has to be kept to ensure RF exposure compliance. The distance between the antennas and the user should not be less than 5.0 cm.

Refer to the Regulatory Statements as identified in the documentation that comes with those products for additional information.

The Toshiba Wireless LAN Mini PCI Card is far below the FCC radio frequency exposure limits.

Nevertheless, it is advised to use the Toshiba Wireless LAN Mini PCI Card in such a manner that human contact during normal operation is minimized.

Interference Statement

This equipment has been tested and found to comply with the limits for a Class B digital device, pursuant to Part 15 of the FCC Rules. These limits are designed to provide reasonable protection against harmful interference in a residential installation. This equipment generates, uses, and can radiate radio frequency energy. If not installed and used in accordance with the instructions, it may cause

harmful interference to radio communications. However, there is no guarantee that interference will not occur in a particular installation.

If this equipment does cause harmful interference to radio or television reception, which can be determined by turning the equipment off and on, the user is encouraged to try and correct the interference by one or more of the following measures:

- ❖ Reorient or relocate the receiving antenna.
- ❖ Increase the distance between the equipment and the receiver.
- ❖ Connect the equipment to an outlet on a circuit different from that to which the receiver is connected.
- ❖ Consult the dealer or an experienced radio/TV technician for help.

Toshiba is not responsible for any radio or television interference caused by unauthorized modification of the devices included with this Toshiba Wireless LAN Mini PCI Card, or the substitution or attachment of connecting cables and equipment other than specified by Toshiba.

The correction of interference caused by such unauthorized modification, substitution or attachment will be the responsibility of the user.

Approved Countries for use

This equipment is approved to the radio standard by the countries in Fig.1.

Australia	Austria	Belgium
Canada	Denmark	Finland
Germany	Iceland	Ireland
Japan	Luxembourg	Netherlands
New Zealand	Norway	Sweden
Switzerland	UK	USA
Greece	Italy	France
Poland	Portugal	Spain

Fig. 1

Caution: Do not use this equipment except in the countries in Fig.1.

CD-ROM / DVD-ROM Safety Instruction

The CD-ROM / DVD-ROM drive employs a laser system. To ensure proper use of this product, please read this instruction manual carefully and retain for future reference. Should the unit ever require maintenance, contact an authorized service location.

Use of controls, adjustments or the performance of procedures other than those specified may result in hazardous radiation exposure.

To prevent direct exposure to the laser beam, do not try to open the enclosure.

Location of the required label

(Sample shown below. Location of the label and manufacturing information may vary.)

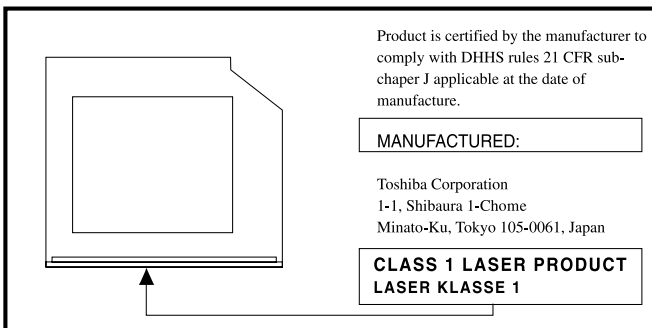

CAUTION: This appliance contains a laser system and is classified as a "CLASS 1 LASER PRODUCT." To use this model properly, read the instruction manual carefully and keep it for your future reference. In case of any trouble with this model, please contact your nearest "AUTHORIZED service station." To prevent direct exposure to the laser beam, do not try to open the enclosure.

CLASS 1 LASER PRODUCT
LASER KLASSE 1

Use of controls or adjustments or performance of procedures other than those specified in the owner's manual may result in hazardous radiation exposure.

Copyright

This guide is copyrighted by Toshiba Corporation, with all rights reserved. Under the copyright laws, this guide cannot be reproduced in any form without the prior written permission of Toshiba. No patent liability is assumed, however, with respect to the use of the information contained herein.

©2000 by Toshiba Corporation. All rights reserved.

Export Administration Regulation

This document contains technical data that may be controlled under the U.S. Export Administration Regulations, and may be subject to the approval of the U.S. Department of Commerce prior to export. Any export, directly or indirectly, in contravention of the U.S. Export Administration Regulations is prohibited.

Notice

The information contained in this manual, including but not limited to any product specifications, is subject to change without notice.

TOSHIBA CORPORATION AND TOSHIBA AMERICA INFORMATION SYSTEMS, INC. (TOSHIBA) PROVIDES NO WARRANTY WITH REGARD TO THIS MANUAL OR ANY OTHER INFORMATION CONTAINED HEREIN AND HEREBY EXPRESSLY DISCLAIMS ANY IMPLIED WARRANTIES OF MERCHANTABILITY OR FITNESS FOR ANY PARTICULAR PURPOSE WITH REGARD TO ANY OF THE FOREGOING. TOSHIBA ASSUMES NO LIABILITY FOR ANY DAMAGES INCURRED DIRECTLY OR INDIRECTLY FROM ANY TECHNICAL OR TYPOGRAPHICAL ERRORS OR OMISSIONS CONTAINED HEREIN OR FOR DISCREPANCIES BETWEEN THE PRODUCT AND THE MANUAL. IN NO EVENT SHALL TOSHIBA BE LIABLE FOR ANY INCIDENTAL, CONSEQUENTIAL, SPECIAL, OR EXEMPLARY DAMAGES, WHETHER BASED ON TORT, CONTRACT OR OTHERWISE, ARISING OUT OF OR IN CONNECTION WITH THIS MANUAL OR ANY OTHER INFORMATION CONTAINED HEREIN OR THE USE THEREOF.

Trademarks

Satellite Pro, Noteworthy, Fn-esse, NoteDock, and AccuPoint II are registered trademarks, SecureSleep, SelectServ, Ask IRIS Online, Active Menu, and VirtualTech are trademarks, and InTouch is a service mark of Toshiba America Information Systems, Inc. and/or Toshiba Corporation.

Intel and Pentium are registered trademarks of Intel Corporation.

IBM is a registered trademark, and PS/2 is a trademark of IBM Corporation.

CompuServe is a registered trademark of America Online, Inc.

DVDEExpress is a trademark of Mediamatics, Inc.

Ethernet is a registered trademark of Xerox, Inc.

LapLink is a registered trademark of Traveling Software, Inc.

Macrovision is a registered trademark of Macrovision, Inc.

MS-DOS, Microsoft, DirectX, DirectShow, and Windows are registered trademarks of Microsoft Corporation; Active Desktop and Media are trademarks of Microsoft Corporation.

RingCentral is a trademark of Ring Zero Systems, Inc.

SoundBlaster Pro is a registered trade mark of Creative Labs, Inc.

SPANWorks 2000 is a trademark of SPANWorks, U.S.A.

Wi-Fi is a trademark of the Wireless Capability Ethernet Alliance.

WorldNet is a registered trademark of AT&T, Inc.

Yahoo! and My Yahoo! are registered trademarks of Yahoo!, Inc.

Yamaha is a registered trademark of Yamaha Corporation.

Energy Star is a registered trademark of the United States Environmental Protection Agency.

Other product names and trademarks belong to the individual companies concerned.

Energy Star® Compliance

As an Energy Star® partner, Toshiba has determined that this product is Energy Star compliant.

Contents

Contents.....	15
Introduction.....	23
This guide.....	23
Safety icons.....	24
Other icons used.....	25
Other documentation.....	25
Service options.....	26
Chapter 1: Finding Your Way Around	27
Making sure you have everything.....	27
Front with the display panel closed	28
Back.....	29
Right side.....	30
Left side.....	31
Underside.....	33
Keyboard and display features.....	34
Front with the display panel open.....	34
Indicator panel lights.....	36

Chapter 2: Getting Started	39
Precautions.....	39
Selecting a place to work.....	40
Creating a computer-friendly environment	40
Keeping yourself comfortable.....	41
Setting up your computer	44
Connecting the modem	44
Connecting to a power source.....	46
Turning on the computer.....	49
Opening the display panel.....	49
Turning on the power	49
Using the AccuPoint II pointing device.....	50
Setting up your software	52
Completing installation.....	53
Registering your computer online	54
Setting up other devices.....	54
Turning off the computer.....	54
Closing the display panel	55
Different ways to turn the computer on and off.....	55
Caring for your computer	56
Cleaning the computer	56
Moving the computer.....	57
Using a computer lock.....	57
Chapter 3: Learning the Basics	59
Computing tips.....	59
Using the keyboard.....	60
Ctrl, Fn, and Alt keys.....	61
Character keys	61
Function keys F1 - F12	61
Windows special keys.....	62
Overlay keys.....	62
Starting a program.....	64
Starting a program from the Start menu.....	65
Starting a program from Windows Explorer	65

Starting a program from the Run dialog box	66
Saving your work	67
Printing your work.....	69
Using diskettes	70
Inserting and removing diskettes	71
Caring for diskettes.....	71
Using compact discs.....	72
Inserting a disc.....	73
Removing a disc	76
Caring for CDs and DVDs.....	77
Backing up your work.....	78
Restoring your work.....	78
Setting up for communications	79
Connecting your computer to a network.....	79
Sending a fax.....	81
Powering down the computer	82
Using Shut down	82
Using Hibernation	85
Using Standby.....	87
Toshiba's online resources	90
Chapter 4: Mobile Computing.....	91
Toshiba's energy-saver design.....	91
Running the computer on battery power.....	92
Maximizing battery life.....	92
Using additional battery packs.....	93
Battery safety precautions.....	93
Charging batteries	93
Charging the battery	93
Charging the RTC battery.....	94
Using a battery charger	95
Monitoring battery power.....	95
Determining remaining battery power	96
What to do when the battery runs low.....	97
Conserving battery power	97

Using Hardware Setup.....	98
Using the Power Saver Utility.....	99
Using a hot key to select the power usage mode.....	100
Turning off the display automatically.....	101
Using battery alarms.....	102
Changing the main battery.....	102
Removing the battery from the computer.....	103
Inserting a charged battery.....	104
Disposing of used batteries safely.....	105
Traveling tips.....	106
Chapter 5: Expansion Options.....	107
Devices for office computing.....	107
Connecting external (optional) devices.....	108
Installing additional memory (optional).....	108
Memory module sizes.....	109
Installing a memory module.....	110
Removing a memory module.....	112
Using an external keyboard.....	114
Making your external keyboard emulate the Fn key....	114
Using a mouse.....	115
Connecting a serial mouse.....	115
Connecting a USB mouse.....	115
Connecting a PS/2 mouse.....	115
Using a printer.....	117
Connecting a parallel printer.....	118
Setting up your printer.....	119
Using an external monitor.....	122
Connecting the display device.....	122
Directing the display output when you turn on the computer.....	124
Adjusting the quality of the external display.....	125
Video limitations.....	125
Using PC Cards.....	126
Inserting a PC Card.....	126

Removing a PC Card	128
Setting up your PC Card for your computer.....	129
Hot swapping PC Cards	129
Using an expansion device.....	130
Chapter 6: Enhancing Productivity	131
Exploring the desktop	131
Finding your way around the desktop.....	131
Exchanging data with another computer	137
Transferring files.....	137
Getting help transferring files.....	138
An overview of using the Internet.....	138
The Internet.....	138
The World Wide Web	139
Internet Service Providers.....	139
Connecting to the Internet.....	139
Surfing the Internet.....	140
Internet features	141
Uploading and downloading files from the Internet ...	141
Exploring audio features	142
Playing an audio CD.....	142
Recording sounds	143
Using external speakers or headphones.....	145
Exploring audiovisual features	146
Playing a DVD.....	146
Playing specific DVD files.....	147
Viewing DVD files on a television	148
Viewing the contents of a CD or DVD	149
Emulating a full-size keyboard	150

Chapter 7: DVDEExpress.....	151
DVDEExpress	151
Starting DVDEExpress.....	152
Status display window	152
DVD Player controls	153
Using the DVDEExpress shortcuts.....	156
Using DVDEExpress options	157
Region codes	158
Chapter 8: Toshiba Utilities.....	159
Fn-esse.....	160
Starting Fn-esse.....	161
Assigning a key to a program or document.....	161
Viewing existing key assignments	163
Changing or removing existing key assignments	164
Toshiba Services	165
Enabling hot key services	165
Toshiba Hardware Setup	166
Toshiba Power Saver utility.....	168
Hibernate tab in Power Management	169
Setting user passwords.....	171
Using an instant password	172
Setting a user password	172
Disabling a user password	172
Using a supervisor password.....	173
Setting a supervisor password.....	173
Deleting a supervisor password.....	175
Chapter 9: If Something Goes Wrong.....	177
Problems that are easy to fix.....	177
Problems when you turn on the computer	180
Windows 98 Second Edition is not working	181
Using Startup options to fix problems.....	182
Internet problems	185
Windows 98 Second Edition can help you	186

Resolving a hardware conflict.....	187
A plan of action.....	187
Resolving hardware conflicts on your own.....	187
Fixing a problem with Device Manager.....	189
Memory card problems.....	191
Power and the batteries.....	191
Keyboard problems.....	193
AccuPoint II problems.....	194
Display problems.....	195
Disk drive problems.....	197
DVD-ROM drive problems.....	199
Sound system problems.....	205
PC Card problems.....	205
Printer problems.....	209
Modem problems.....	210
Develop good computing habits.....	210
Use VirtualTech.....	212
If you need further assistance.....	213
Before you call.....	213
Contacting Toshiba.....	213
Other Toshiba Internet Web sites.....	214
Toshiba's worldwide offices.....	215

Appendix A: Hot Keys	219
Appendix B: Features and Specifications.....	223
Appendix C: Power Cable Connectors	231
Appendix D: Video Modes.....	233
Glossary	235
Index.....	249

Introduction

Welcome to the world of powerful, portable multimedia computing. With your new Toshiba notebook computer, your work can accompany you wherever you go.

Satellite Pro computers provide considerable computing power, enabling you to perform the most demanding computing tasks from any location.

You will find that your operating system, Microsoft® Windows® 98 Second Edition, is already installed on your computer. It offers exciting features and easy Internet access.

This guide

This guide introduces the computer's features. You can:

- ❖ Read the entire guide from beginning to end
- ❖ Skim through and stop when a topic interests you
- ❖ Use the tables of contents and the index to find specific information

If you are new to computers or have not used a notebook computer before, read through this chapter to familiarize yourself with the components of the computer. After that, seek out whatever interests you most.

Safety icons

This guide contains safety instructions that must be observed in order to avoid potential hazards that could result in personal injuries, damage to your equipment, or loss of data. The safety instructions have been classified according to the seriousness of the risk, and the following icons highlight these instructions:



DANGER: This icon indicates the existence of a hazard that could result in death or serious bodily injury if the safety instruction is not observed.



WARNING: This icon indicates the existence of a hazard that could result in bodily injury if the safety instruction is not observed.



CAUTION: This icon indicates the existence of a hazard that could result in damage to equipment or property if the safety instruction is not observed.



NOTE: This icon indicates information that relates to the safe operation of the equipment or related items.

Other icons used

Additional icons highlight other helpful or educational information:



TECHNICAL NOTE: This icon indicates technical information about the computer.



HINT: This icon indicates helpful hints and tips.



DEFINITION: This icon indicates the definition of a term used in the text.

Other documentation

Your computer comes with the following documentation in addition to this user's guide:

- ❖ Guides for other software that may come preinstalled on your computer and for additional programs on the Configuration Builder CD.
- ❖ The *Toshiba Companion Diskette Guide* explains when to use the Toshiba Companion Diskette and how to use the programs on the diskette that are not discussed in this guide.
- ❖ The Microsoft Windows operating system documentation explains the features of the Windows operating system.
- ❖ The accessories information package with your computer lists the accessories available from Toshiba and explains how to order them.

The Configuration Builder CD contains the programs that are preinstalled at the factory, should you need to reinstall them. This CD-ROM allows you to restore the hard disk drive to the factory image, create a custom preinstall, and/or install individual drivers, applications, and utilities.

Service options

Toshiba offers a full line of service options built around its SelectServ™ warranty programs. See the warranty and service material included with your computer for registration information.

If you have a problem or need to contact Toshiba, see [If Something Goes Wrong](#) on page 177.

Chapter 1

Finding Your Way Around

This chapter presents a grand tour of your Satellite Pro computer. It serves as a reference when you need to locate specific parts of the computer.

Making sure you have everything

Before you do anything else, consult the Quick Start card shipped with your computer to make sure you received everything.

If any items are missing or damaged, notify your authorized Toshiba representative or your network administrator immediately. For additional help, see [If Something Goes Wrong on page 177](#).

Front with the display panel closed

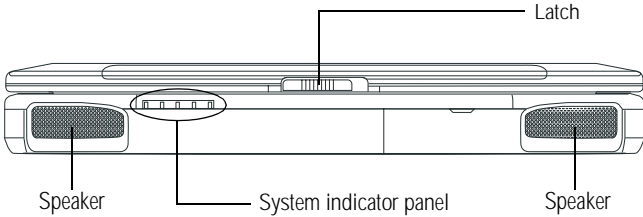







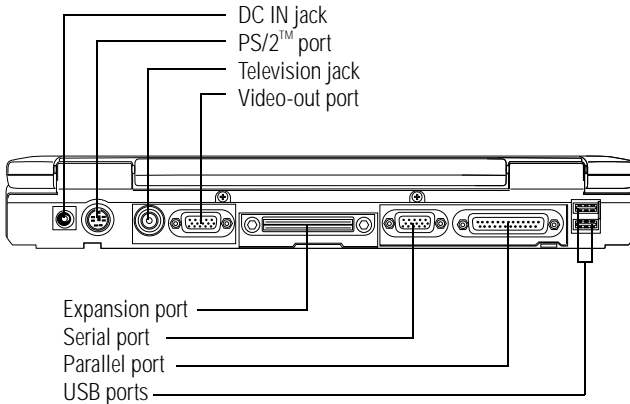

Sliding the display latch opens the computer's display panel. For more information, see [Keyboard and display features on page 34](#).

The integrated stereo bass reflex speaker system supports sound output for .wav files, MIDI playback, and audio from the DVD-ROM drive. The speakers also support audio from external devices, such as a tape deck or stereo tuner, through the microphone jack (or through the line-in jack on an optional expansion device).

The system indicator panel consists of several lights that provide information about various system functions. For more information, see [System indicator panel on page 37](#).

Back



-  The DC IN jack enables you to connect the AC adapter to the computer. For more information, see [Connecting to a power source on page 46](#).
-  The PS/2 port allows you to connect an optional PS/2-compatible mouse or external keyboard to the computer. Alternatively, you can attach an optional Y-cable to connect both a PS/2 compatible keyboard and a PS/2 mouse simultaneously.
-  Use the television jack to connect a television to the computer.
-  Use the video-out port to connect an external monitor.
-  The expansion port allows you to connect the computer to an optional port replicator.
-  Use the serial port to connect a serial mouse, serial printer, or other serial device.
-  The parallel port allows you to connect a parallel printer or other parallel device.



Use the two USB (Universal Serial Bus) ports to connect USB peripherals to the computer.



DEFINITION: USB is a peripheral expansion standard that supports data transfer rates up to 12 Mbps for peripherals such as keyboards and pointing devices. USB peripherals have a single standard for cables and connectors. The USB standard also allows hot swapping of peripherals.

Right side

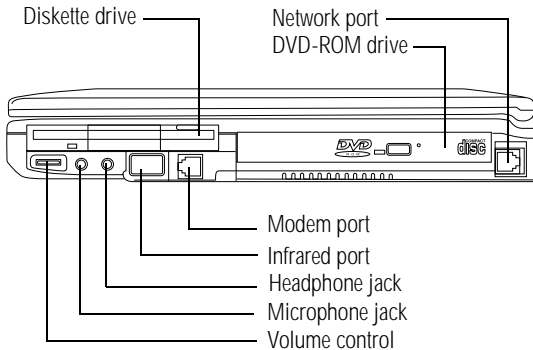

The diskette drive allows you to use 3.5-inch diskettes to store your work or install software. For more information, see [Using diskettes on page 70](#).



The RJ45 jack provides access to a LAN via a standard Ethernet[®] network cable.

The DVD-ROM drive allows you to use DVDs and compact discs with the computer. You can use it to install and run programs from CD-ROMs and to play audio CDs. For more information, see [Starting DVDEExpress on page 152](#).



The modem port enables you to connect the built-in modem to a standard telephone line.



The infrared port provides a cable-free connection for transferring data between your computer and another device, such as a printer or another computer, that has a compatible infrared port.



The headphone jack allows you to connect stereo headphones or other audio-output devices, such as external speakers, to the computer. Connecting headphones or other devices to this jack automatically disables the internal speakers.



The microphone jack allows you to connect an external monaural microphone or other audio input device to the computer.



The volume control dial allows you to adjust the volume of the computer's speakers.

Left side

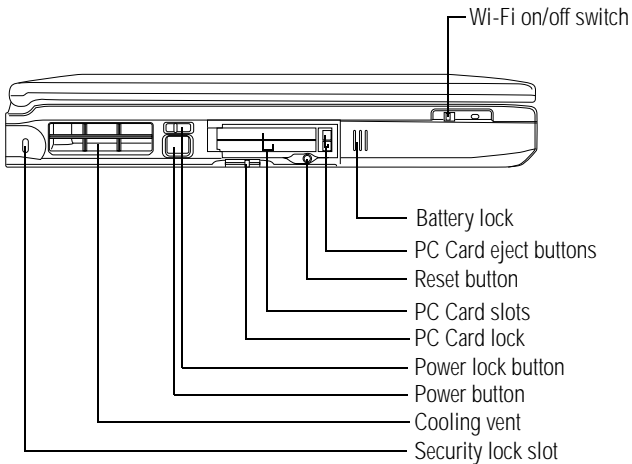

The 802.11b (now referred to as Wi-Fi™ — wireless fidelity) on/off switch turns the optional wireless communication system on or

off. For more information on wireless functionality, see [Connecting your computer to a network on page 79](#).



NOTE: For environments that do not permit wireless use or instruct you to turn off all radio devices (for example, aboard commercial aircraft), you should turn the Wi-Fi switch off.

The battery lock releases the battery. For more information, see [Changing the main battery on page 102](#).



The upper PC Card eject button releases the PC Card from the upper PC Card slot.



The lower PC Card eject button releases the PC Card from the lower PC Card slot.



CAUTION: Keep foreign objects out of the PC Card slots. A pin or similar object can damage the computer's circuitry.



Pressing the reset button enables you to restart the computer when it is not responding to the keyboard. This overrides the Standby command. Only use the reset button when all other attempts at restarting the computer have failed.



CAUTION: Never use a pencil to press the reset button. Pencil lead can break off inside the computer and damage it. Instead, use a slim object such as a straightened paper clip.



The PC Card slots allow you to connect PCMCIA-compatible devices to the computer. These slots can accommodate two Type I or Type II PC Cards, or one Type III PC Card. For more information, see [Using PC Cards on page 126](#).



The PC Card lock allows you to secure your PC Cards in the slots. Slide the button to the right to lock the PC Cards.



The power lock button prevents you from accidentally turning the computer on or off. Slide the button to the left when you want to use the power button.



Pressing the power button turns the computer on or off, provided you have released the power button lock.

The cooling vent supplies air for the fan.



CAUTION: To prevent the CPU from overheating, avoid blocking the cooling vent.



The security lock slot allows you to attach the optional PORT-Noteworthy® Computer Lock cable to the computer to secure it to a large, heavy object such as your desk.

Underside

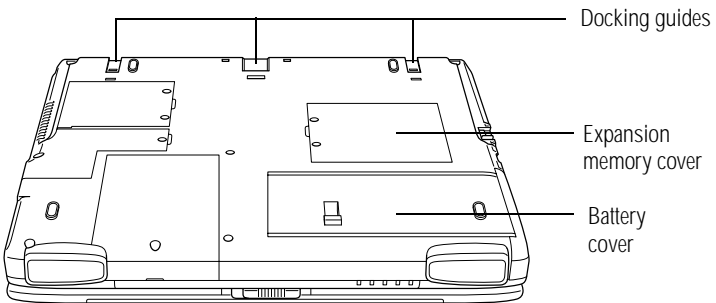

The docking guides help you to align the computer with, and secure it to, the optional port replicator.



The expansion memory cover protects the slot in which you can install up to two memory modules. For more information on expanding your computer's memory, see [Installing additional memory \(optional\)](#) on page 108.



The battery cover houses and protects the main battery. It has an integrated release latch that secures the battery to the computer

case. For information on replacing the battery, see [Changing the main battery on page 102](#).

Keyboard and display features

Front with the display panel open

To view the front of the computer with the display panel open:

- 1 Locate the display latch on the front of the computer.

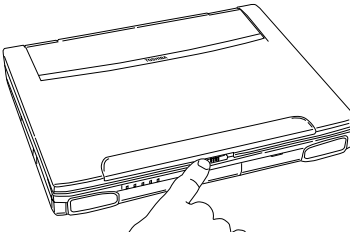

Releasing the display latch

- 2 Slide the display latch to the right and lift the display panel.

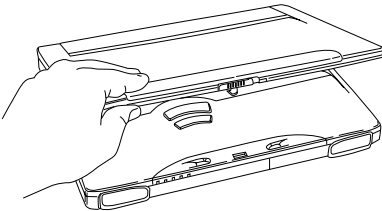

Opening the display panel

- 3 Adjust the display panel to a comfortable viewing angle.



CAUTION: To avoid damaging the display panel, be careful when opening and closing it. Never force the panel beyond the point where it moves easily, and never use it to lift the computer.

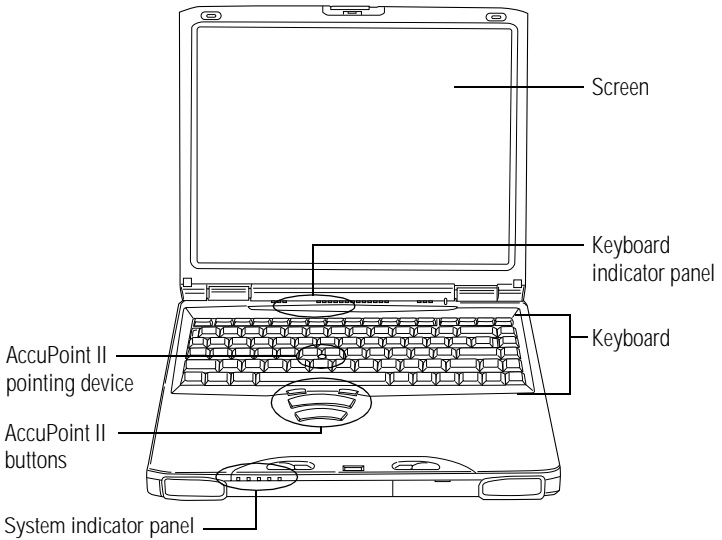

The keyboard panel contains the following computer components:

- ❖ Screen
- ❖ Keyboard indicator panel
- ❖ Keyboard
- ❖ AccuPoint® II pointing device and control buttons
- ❖ System indicator panel

Screen

The computer's screen is a Poly-Silicon Technology, Thin Film Transistor (TFT), liquid crystal display (LCD) that provides clear, sharp images.

For more information about using an external monitor, see [Using an external monitor on page 122](#).

Keyboard

The 85-key keyboard provides all the functionality of a full-size keyboard. It has several built-in hot-key functions that turn system functions on and off. For more information on how to use the internal keyboard, see [Using the keyboard on page 60](#). For information on using an external keyboard, see [Using an external keyboard on page 114](#).

AccuPoint II pointing device

The AccuPoint II pointing device combines the function of a mouse with the convenience of never having to remove your hands from the keyboard. The AccuPoint II buttons work with the AccuPoint II pointing device. For further information, see [Using the keyboard on page 60](#).

Indicator panel lights

Keyboard indicator panel

The keyboard indicator panel consists of three lights that provide information on which keyboard functions are enabled.



Caps lock mode



Cursor control mode



Numeric mode

Keyboard indicator panel



The caps lock mode light glows when you press the caps lock key. When this light is on, pressing a letter key on the keyboard produces an uppercase (capital) letter. The caps lock key does not affect the number and symbol keys.



The cursor control mode light glows when the cursor control overlay is on. When this light is on, pressing an overlay key moves the cursor as shown by the grey arrow or command printed on the

left front of the key instead of the letter printed on the top of the key. For more information on the cursor control overlay keys, see [Overlay keys on page 62](#).



The numeric mode light glows when the numeric overlay is on. When this light is on, pressing an overlay key produces the grey number printed on the right front of the key instead of the letter printed on the top of the key. For more information on the numeric overlay keys, see [Using the numeric keypad overlay on page 63](#).

System indicator panel

The system indicator panel consists of five lights that provide information about the current state of your computer.

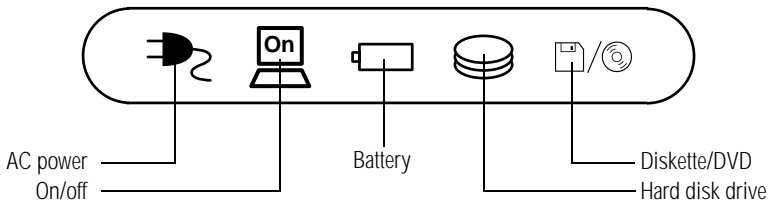

System indicator panel



The AC power light shows the power status of the AC adapter.

- ❖ No illumination means that the AC adapter is not connected.
- ❖ Green means the system is in its operating state, and is receiving power from the AC adapter.
- ❖ Flashing amber means there may be a problem with the AC adapter, the battery, or the computer. Unplug the AC adapter, remove the battery, and reinstall it. See [Changing the main battery on page 102](#).



The on/off light indicates whether the computer's power switch is turned on and if the computer is in Standby mode.

- ❖ No illumination means the power switch is turned off with the computer in boot mode.

- ❖ Green means the power switch is turned on, and power is being supplied.
- ❖ Flashing, in two-second intervals, means the power switch is turned off and the computer is in Standby mode. For more information about Standby mode, see [Using Standby on page 87](#).



The battery light indicates the status of the computer's battery.

- ❖ No illumination means the battery has completely discharged and the AC adapter is not connected.
- ❖ Green means the battery is fully charged.
- ❖ Amber means the battery is charging (AC adapter connected.)
- ❖ Flashing amber means the battery charge is low and it is time to recharge the battery or plug in the AC adapter.

For more information see [Monitoring battery power on page 95](#).



The hard disk drive light indicates whether the internal hard disk drive is currently in use.

- ❖ No illumination means the hard disk drive is idle.
- ❖ Green or flashing means that the hard disk drive is being accessed.



HINT: To avoid data loss, never turn off the computer while any drive is being accessed.



The diskette/DVD light shows the computer's diskette drive and DVD-ROM drive activity:

- ❖ No illumination means the diskette drive and DVD-ROM drive are idle.
- ❖ Green means the diskette drive or the DVD-ROM drive is in use.

Chapter 2

Getting Started

This chapter provides tips for working comfortably, summarizes how to connect components, and explains what to do the first time you use your notebook computer.

Precautions

- ❖ Avoid spilling liquids on the keyboard.

If you do spill a liquid that gets into the keyboard, turn off the computer immediately. Leave the computer off overnight to give it time to dry out before you use it again.

- ❖ Never turn off the computer if a drive indicator light indicates the drive is in use.

Turning off the computer while it is reading from or writing to a disk may damage the disk, the drive, or both.

- ❖ Keep the computer and diskettes away from objects that generate strong magnetic fields, such as large stereo speakers.

Information on diskettes is stored magnetically. Getting a magnet too close to a diskette can erase important files.

- ❖ Scan all new files for viruses.

This precaution is especially important for files you receive via diskette, email, or download from the Internet.

Selecting a place to work

Your computer is portable and designed to be used in a variety of circumstances and locations.

Creating a computer-friendly environment

Place the computer on a flat surface that is large enough for the computer and any other items you need to use, such as a printer. Leave enough space around the computer and other equipment to provide adequate ventilation. Otherwise, the equipment may overheat.

To keep your computer in prime operating condition, protect your work area from:

- ❖ Dust, moisture and direct sunlight
- ❖ Liquids and corrosive chemicals



CAUTION: If you spill liquid into the computer, turn it off, unplug it from the AC power source and let it dry out completely before turning it on again.

If the computer does not operate properly after you turn it back on, contact a Toshiba service representative or your network administrator.

- ❖ Equipment that generates a strong electromagnetic field, such as stereo speakers (other than speakers that are connected to the computer), or speakerphones
- ❖ Rapid changes in temperature or humidity and sources of temperature change such as air conditioner vents or heaters

- ❖ Extreme heat, cold, or humidity. Operate the computer within a temperature range of 41 to 95 degrees Fahrenheit (5 to 35 degrees Celsius) and 20 percent to 80 percent non-condensing humidity

Keeping yourself comfortable

Strain and stress injuries are becoming more common as people spend more time using their computers. With a little care and proper use of the equipment, however, you can work comfortably throughout the day.



WARNING: Using the computer keyboard incorrectly may result in discomfort and possible injury. If your hands, wrists, and/or arms bother you while typing, stop using the computer and rest. If the discomfort persists, consult a physician.

This section provides hints on avoiding strain and stress injuries. For more information, consult books on ergonomics, repetitive-strain injury, and repetitive-stress syndrome.

Placement of the computer

Proper placement of the computer and external devices is important to avoid stress-related injuries:

- ❖ Place the computer on a flat surface at a comfortable height and distance. You should be able to type without twisting your torso or neck and look at the screen without slouching.
- ❖ If you use an external monitor, the top of the screen should be no higher than eye level.
- ❖ If you use a paper holder, set it at the same height and distance as the screen.

Seating and posture

When using your computer, maintain good posture with your body relaxed and your weight distributed evenly. Proper seating is a primary factor in reducing work strain. Some people find a backless chair more comfortable than a conventional chair. Whichever type you choose, use the following guidelines to adjust your chair for maximum computing comfort.

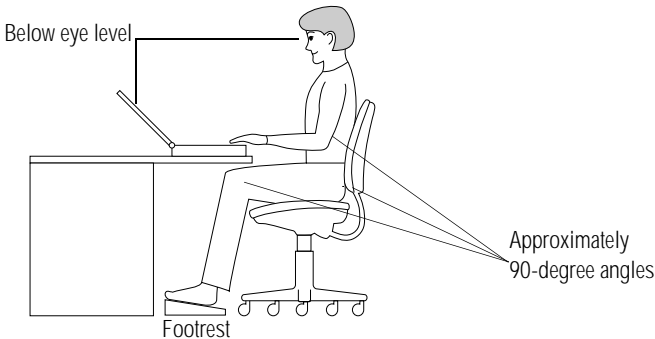

Correct posture and computer placement

- ❖ Position your chair so that the keyboard is at or slightly below the level of your elbow. You should be able to type comfortably with your shoulders relaxed and your forearms parallel to the floor.

If you are using a conventional chair:

- ❖ Your knees should be slightly higher than your hips. If necessary, use a footrest to raise the level of your knees and ease the pressure on the back of your thighs.
- ❖ Adjust the back of your chair so that it supports the lower curve of your spine. If necessary, use a cushion to provide extra back support. Lower-back-support cushions are available at many office supply stores.

- ❖ Sit with your back straight so that your knees, hips, and elbows form approximately 90-degree angles when you work. Don't slump forward or lean back too far.

Lighting

Proper lighting can improve the visibility of the display and reduce eyestrain.

- ❖ Position the display panel or external monitor so that sunlight or bright indoor lighting does not reflect off the screen. Use tinted windows or shades to reduce glare.
- ❖ Avoid placing your computer in front of a bright light that could shine directly in your eyes.
- ❖ If possible, use soft, indirect lighting in your computer work area.

Arms and wrists

- ❖ Avoid bending, arching, or twisting your wrists. Keep them in a relaxed, neutral position while typing.
- ❖ Exercise your hands, wrists and arms to improve circulation.

Work habits

The key to avoiding discomfort or injury from strain is to vary your activities. If possible, schedule a variety of tasks into your work day. Finding ways to break up the routine can reduce stress and improve your efficiency.

- ❖ Take frequent breaks to change position, stretch your muscles, and relieve your eyes. A break of two or three minutes every half hour is more effective than a long break after several hours.
- ❖ Avoid performing repetitive activities for long periods. Intersperse such activities with other tasks.

- ❖ Focusing your eyes on your computer screen for long periods can cause eyestrain. Look away from the computer frequently and focus your eyes on a distant object for at least thirty seconds.

Setting up your computer

Your computer comes with a rechargeable battery pack that must be charged before you can use it.

To use external power or to charge the battery, you must attach the AC adapter. See [Connecting to a power source on page 46](#).

To register your computer online, or to sign up for an Internet account, you must connect the built-in modem to a telephone line.

Before starting to use your computer, you may also want to:

- ❖ Add more memory
- ❖ Connect a mouse
- ❖ Connect a full-size keyboard
- ❖ Connect an external monitor
- ❖ Connect a local printer
- ❖ Install PC Cards
- ❖ Connect a port replicator

If you want to add any of these devices to the computer, you should do so before you turn on the computer. For more information, see [Expansion Options on page 107](#).

Connecting the modem

Before you can communicate using the computer's built-in modem, you need to connect it to a standard voice-grade telephone line.



- 1 Plug one end of a standard telephone cable (provided) into the computer's modem port.

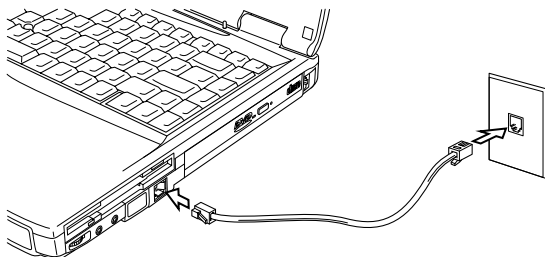

Connecting the telephone cable to the modem port

- 2 Connect the other end of the telephone cable to the jack of a standard analog telephone line.



CAUTION: Don't connect the modem to a digital telephone line. A digital line will damage the modem.

For information on using a modem, see [Setting up for communications on page 79](#).



HINT: If you're using a telephone line at home, disable Call Waiting before you connect through the modem. Call Waiting interrupts transmission.

Connecting to a power source

The AC adapter allows you to power the computer from an external AC power source and to charge the computer's batteries.

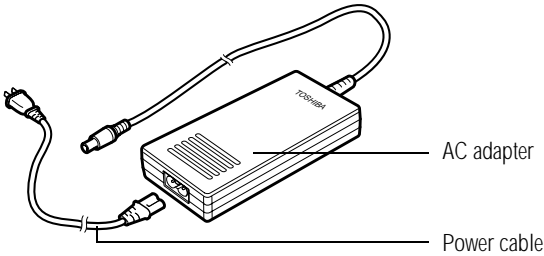

Power cable and AC adapter



CAUTION: Use of the wrong AC adapter could damage your computer. Toshiba assumes no liability for any damage in such cases.

Never pull directly on the power cable to unplug it. Hold the power plug when removing the cable from the outlet.

To connect the computer to an external power source:

- 1** Connect the socket end of the power cable to the AC adapter.

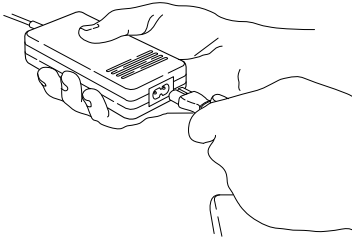

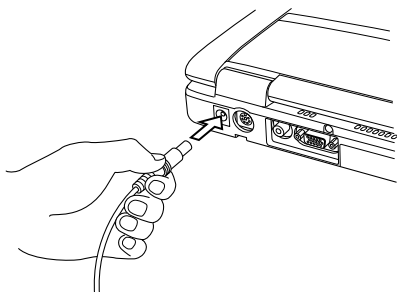

Connecting the power cable to the AC adapter

- ② 2 Connect the DC OUT end of the AC adapter cable to the DC IN jack at the back of the computer.



Connecting the AC adapter cable to the computer

- 3 Insert the plug end of the power cable into a live wall outlet.
The AC power light  on the system indicator panel glows green.

If the main battery is present, the battery light  glows:

- ❖ Amber while the battery is charging
- ❖ Green when the battery is fully charged

If the AC power light flashes amber during charging, either the battery pack is malfunctioning, or it is not receiving input from the AC power supply.

Disconnect the AC cable and remove the battery pack. See [If Something Goes Wrong on page 177](#) for troubleshooting information.



DANGER: Damaged power cables can cause fire or electric shock. Never modify, forcibly bend, place heavy objects on top of, or apply heat to the power cable.

If the power cable becomes damaged or the plug overheats, discontinue use. There is a risk of electric shock.

Never remove the power plug from the outlet with wet hands. Doing so may cause an electric shock.

Charging the battery

Your computer came with its battery already installed. Before using the battery to power the computer, you must charge it.

To charge the battery, leave the computer plugged in to an AC power source for at least three hours with the computer turned off. After that, the battery will be completely charged and ready to power the computer.

For more information on using the battery, see [Running the computer on battery power on page 92](#).



CAUTION: Once the battery is charged for the first time, avoid leaving the computer plugged in and turned off for more than a few hours at a time. Continuing to charge a fully charged battery can damage the battery.

Turning on the computer

The computer is now ready for you to turn it on and begin using it.

Opening the display panel

To open the display panel, slide the latch to the right and lift the display panel. For more information, see [Keyboard and display features on page 34](#).



CAUTION: To avoid damaging the display panel, don't force it beyond the point where it moves easily.

Never lift or move the computer using the display panel.

Turning on the power

- 1 Make sure any external devices (such as a local printer) are properly connected and ready.
- 2 Check that the diskette drive is empty.
- 3 If the battery is not charged, connect the AC adapter. For more information, see [Connecting to a power source on page 46](#).

The AC power light (🔌) glows green if the AC adapter is properly connected to the computer.

The battery light (🔋) glows amber while the battery is charging and glows green when the battery is fully charged and ready to power the computer.



- 4 Locate the power button lock on the left side of the computer and slide it to the left (the unlocked position).



- 5 Press and hold the power button until the system indicator panel's on/off light glows green.

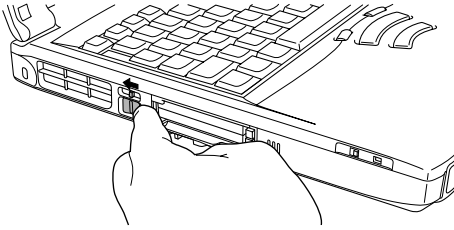

Releasing the power button lock and turning on the power

The preinstalled operating system loads automatically.



The hard disk drive light flashes as the computer accesses the hard disk.



NOTE: If you are turning on the computer for the first time, don't turn it off until the operating system has loaded completely.

To avoid data loss, never turn off the computer while any of the drives are in use. The hard disk drive and diskette/DVD-ROM drive lights illuminate when the drive is being accessed.

For information on turning off the computer, see [Turning off the computer on page 54](#).

Using the AccuPoint II® pointing device

The button in the middle of the keyboard is the AccuPoint II pointing device. Together with the primary and secondary AccuPoint II buttons, it provides the same functionality as a mouse — it enables you to move the cursor and to select items on the screen.

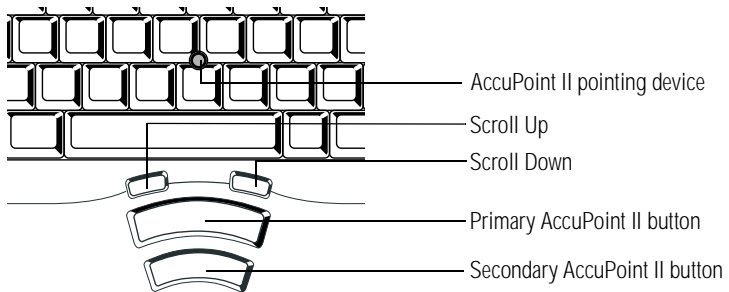

AccuPoint II pointing system



HINT: If you would rather use a mouse or trackball, you can connect one to the computer's serial port, USB port, or PS/2 port. For information, see [Using a mouse](#) on page 115.

To move the cursor, gently push the AccuPoint II pointing device in the direction you want the cursor to move. Pushing harder on the AccuPoint II pointing device moves the cursor faster.

The primary AccuPoint II button corresponds to the primary (typically left) mouse button. When a step instructs you to click or choose an item, move the cursor to the item, then press and release the primary AccuPoint II button. To double-click, press the primary AccuPoint II button twice in rapid succession.

The secondary button acts as the secondary (typically right) mouse button. The function of the secondary AccuPoint II button depends on the program you are using. Check your program's documentation to determine whether it uses the right mouse button.

The small left button performs the scroll up function.

The small right button performs the scroll down function.

Setting up your software

Your computer comes with Microsoft Windows 98 Second Edition preinstalled. For specific questions about your operating system or other software that may come preinstalled on your computer, refer to the documentation that comes with your computer.

To help you get started, Windows 98 Second Edition guides you through several essential steps for setting up your computer.

- ❖ **Completing installation** — Enables you to enter details to authenticate and personalize your copy of Windows 98 Second Edition.
-  ❖ **Registration** — Allows you to register your Toshiba computer online, send your Windows 98 Second Edition registration information to Microsoft, and upgrade or extend your Toshiba warranty.



NOTE: To perform online operations, your computer must be connected to a voice-grade telephone line. See [Connecting the modem on page 44](#).

- ❖ **Internet Access** — Guides you through signing up for a new Internet account with AT&T WorldNet[®] Service, or assists you in setting up your computer to work with your existing Internet account. If you choose to sign up for Internet access with AT&T WorldNet, you will not be charged for the call.

Toshiba and Yahoo![®] have joined together to offer you a free account on Yahoo!. In order to sign up for Yahoo!, you must have an Internet access account.
- ❖ **Final Settings** — Completes your Windows setup. During this step you will be prompted to set the current date and time. Press the ESC key on the keyboard to exit Setup and display the Windows desktop.

Completing installation

The first time you turn on the computer, Windows Setup installs the devices it finds on your system. Setup then displays the Finishing Setup screen.

- 1 Click **Finish** to restart the computer.
- 2 In the User Information screen, type your name and company in the appropriate boxes, then click **Next**.
- 3 Read the license agreement, click the button labeled **I accept the agreement**, then click **Next**.
- 4 In the Certificate of Authentication screen, type the number from the certificate affixed to the Windows 98 Second Edition manual that came with your computer, then click **Next**.
- 5 Click **Finish**.

Setup displays the Date/Time Properties box.

Setting your time zone, date, and time

The Date/Time Properties dialog box has two tabs. Click on a tab to make it active.

- ❖ On the Time Zone tab, select your time zone by clicking the up and down arrow keys.
- ❖ On the Date and time tab, set the correct date and time, if necessary.

Completing the initial startup procedure

Setup displays the Welcome to Windows 98 (Second Edition) screen, which provides several options to show additional information or install additional features.



When you have finished looking at any or all of these, click the **Close** button on the Welcome to Windows 98 (Second Edition) screen to start the operating system.

Registering your computer online

The first time you use your computer, you will be prompted to complete and mail the registration card or to register your computer with Toshiba online.

To register your computer online at a later time, double-click the icon provided on the desktop and follow the instructions on the screen.

Registering your computer lets Toshiba keep you up-to-date with information about new products and upgrades and also extends your Toshiba warranty worldwide at no charge to you. See the registration card and warranty information for details about warranty options available from Toshiba.

Setting up other devices

You may want to take this time to set up your printer. For more information, see [Setting up your printer on page 119](#).

Turning off the computer

It's generally a good idea to turn off your computer when you are not using it.

If you are using the computer for the first time, leave the computer plugged into a power source (even though the computer is off) to fully charge the main battery. With the computer off, it may take up to three hours to recharge the main battery.

Guidelines for turning off the computer:

- ❖ If you have work in progress and aren't connected to a network, use the Windows Standby command to save your system settings to memory so that, when you turn on the computer again, you automatically return to where you left off.

- ❖ To leave the computer off for a longer period, use the Windows Shut Down command. Another option is to use Hibernation mode to save the system settings to the hard disk. For more information, see [Powering down the computer on page 82](#).
- ❖ Never turn off the power while a disk light on the system indicator panel is on. Doing so may damage your hard disk, diskette drive, or DVD-ROM drive.
- ❖ To avoid accidentally turning on the computer, slide the power button lock right to the locked position.

Closing the display panel

When you are finished, shut the computer down and close the display panel to keep dust and dirt out of the computer.

If you close the computer while it is still on, one of the following actions will occur:

- ❖ If you have the LCD power-saver feature set, the LCD panel will automatically turn off until you open it again.
- ❖ If you have the audible warning set, the computer will beep to notify you that it is still on. (See [Toshiba Hardware Setup on page 166](#).)
- ❖ If you have an action feature set, the computer will perform that action (Nothing, Standby, Hibernate, Shutdown). For more information, see [Hibernate tab in Power Management on page 169](#).

Different ways to turn the computer on and off

Instead of turning on your computer by pressing the power button, you can:

- ❖ Set the computer to turn on automatically at a time you designate. This option is helpful if you want to transfer files by modem at night, when the rates are cheaper. You can set

the computer to turn on and send or receive the files while you are asleep. This option is called Auto Power On.

- ❖ Turn the computer on and off by opening and closing the display panel. This option is a convenient way to turn on the power, and prevents you from closing the display panel while the computer is on. This option is called Panel Power On/Off.



NOTE: Pushing the power button before shutting down Windows could cause you to lose your work. Make sure the system indicator panel's disk light and the diskette/DVD-ROM-in-use drive light are off. If you turn off the power while a disk is being accessed, you may lose data or damage the disk.

Caring for your computer

This section gives tips on cleaning and moving your computer. For information about taking care of your computer's main battery, see [Running the computer on battery power on page 92](#).

Cleaning the computer



CAUTION: Keep liquid, including cleaning fluid, out of the computer's keyboard, speaker grille and other openings. Never spray cleaner directly onto the computer. Never use harsh or caustic chemical products to clean the computer.

To keep your computer clean, gently wipe the display panel and exterior case with a lightly dampened cloth. Ask your Toshiba sales representative or your network administrator for suggestions for appropriate cleaning products.

Moving the computer

Before moving your computer, even across the room, make sure that all disk activity has ended and all external peripheral cables are disconnected.



CAUTION: Never pick up the computer by its display panel or by the back (where the ports are located).

Although your notebook computer is built to withstand reasonable shock and vibration, transport it in a carrying case for long trips. You can purchase a carrying case from your Toshiba dealer or through Toshiba's Web site at www.toshibaaccessories.com.

Using a computer lock

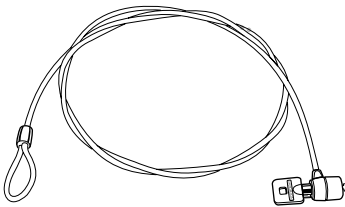

You may want to secure your computer to a heavy object such as your desk. The easiest way to do this is to purchase an optional PORT-Noteworthy Cable Lock.



PORT-Noteworthy computer lock cable

To secure the computer:

- 1** Loop the cable through or around some part of a heavy object. Make sure there is no way for a potential thief to slip the cable off the object.
- 2** Pass the locking end through the loop.

-  **3** If a PC Card is installed, slide the PC Card lock to the right to secure the card in the PC Card slot.
-  **4** Insert the cable's locking end into the security lock slot on the computer, give the key a quarter turn and remove it.

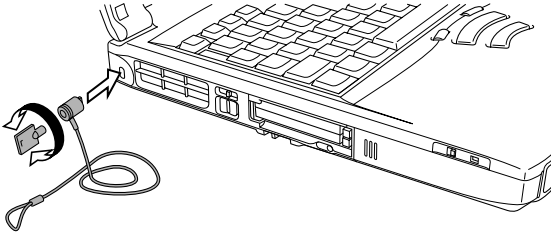

Securing the computer

The computer is now securely locked.

Chapter 3

Learning the Basics

This chapter gives some computing tips and provides important information about basic features.

Computing tips

- ❖ Save your work frequently.

Your work stays in the computer's temporary memory until you save it to the disk. If the network you are using goes down and you must restart your computer to reconnect, or your battery runs out of charge while you are working, you will lose all the work since you last saved.

See [Saving your work on page 67](#) for further information.



HINT: Some programs have an automatic save feature that can be activated. This feature saves your file to the hard disk at preset intervals. See your software documentation for details.

- ❖ Back up your files to diskettes (or other removable media) on a regular basis. Label the backup copies clearly and store them in a safe place.

It is easy to avoid backing up your files because it takes time. However, if your hard disk suddenly fails, you will lose all the data on it unless you have a separate backup copy.

- ❖ Use ScanDisk and Disk Defragmenter regularly to conserve disk space and improve performance. Consult your Windows documentation for instructions.
- ❖ Before turning off the computer, use the Shut Down command or Standby command. See [Powering down the computer on page 82](#) to learn more about Standby.



NOTE: Windows 98 Second Edition records information, such as your desktop setup, during its shutdown procedure. If you don't let Windows 98 Second Edition shut down normally, details such as new icon positions may be lost.

Using the keyboard

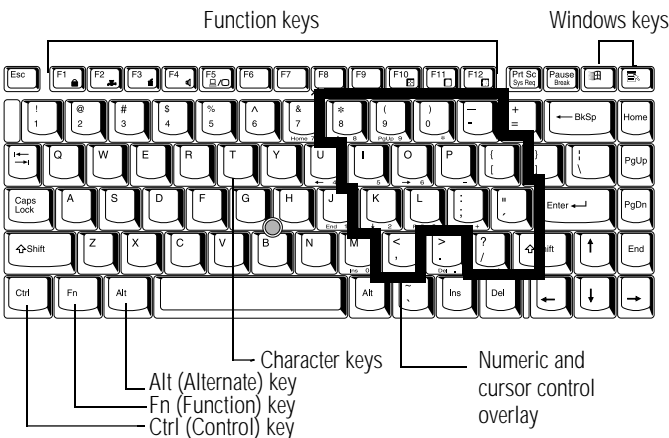

Parts of the keyboard

Ctrl, Fn, and Alt keys



Ctrl, Fn and Alt keys

The Ctrl, Fn, and Alt keys do different things depending on the program you are using. For more information, see your program documentation.

Character keys

Typing with character keys is very much like typing on a typewriter, except:

- ❖ The spacebar creates a space character instead of just passing over an area of the page.
- ❖ The lowercase l (el) and the number 1 are not interchangeable.
- ❖ The uppercase letter O and the number 0 (zero) are not interchangeable.
- ❖ The Caps Lock key changes only the alphabet keys to uppercase — the number and symbol keys are not affected.

Function keys F1 - F12

The function keys (not to be confused with the Fn key) are the 12 keys at the top of the keyboard.



Function keys

F1 through F12 are called function keys because they run programmed functions when you press them. Used in conjunction with the Fn key, function keys marked with icons run specific functions in the computer.

Windows special keys

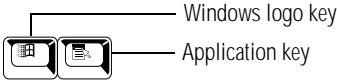

Windows special keys

The keyboard provides two keys that have special functions in Windows 98 Second Edition.

- ❖ The Windows logo key activates the Start menu.
- ❖ The Application key has the same function as the secondary button of the AccuPoint II pointing device (or right mouse button).

Overlay keys

The keys with grey numbers and symbols on the front of them form the numeric and cursor overlay. This overlay lets you enter numeric data or control the cursor as you would using the ten-key keypad on a full-size keyboard.

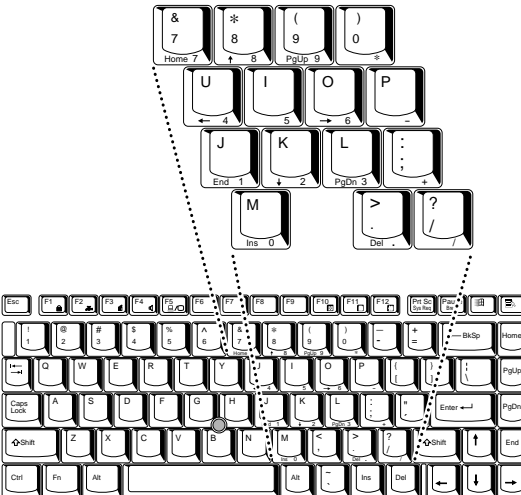

Keyboard overlay keys

Using the numeric keypad overlay

The keys with the numbers on the right front of the keycaps are the numeric keypad overlay.



To turn the numeric overlay on, press Fn and F11 simultaneously. The numeric mode light on the keyboard indicator panel glows when the numeric overlay is on.

You can still use the overlay keys to type alphabetic characters while the numeric overlay is on.

Once the numeric overlay is turned on:

<i>To</i>	<i>Procedure</i>
Type lowercase letters	Press and hold down Fn while you type the letters
Type uppercase letters	Press Fn and Shift simultaneously while you type the letters
Use the cursor control keys	Press and hold down Shift while you use the overlay keys, then release Shift to return to the numeric overlay

To turn off the numeric overlay, hold down the Fn key and press F11 again. The numeric mode light on the keyboard indicator panel goes out.

Using the cursor control overlay



To turn on the cursor control overlay, press Fn and F10 simultaneously. The cursor control mode light on the keyboard indicator panel glows when the cursor control overlay is on.

Once the cursor control overlay is on:

<i>To</i>	<i>Procedure</i>
Type lowercase letters	Press and hold down Fn while you type the letters
Type uppercase letters	Press Fn and Shift simultaneously while you type the letters
Use the numeric keys	Press and hold down Shift while you use the overlay keys, then release Shift to return to the cursor control overlay

To turn off the cursor control overlay, hold down the Fn key and press F10 again. The cursor control mode light on the keyboard indicator panel goes out.

Starting a program

The easiest way to start a program is to double-click the name of the file that contains the information you want to work on. To find the file, use My Computer or Windows Explorer.

If you prefer to open the program first, you have four options. You can:

- ❖ Double-click the icon for the program on your desktop
- ❖ Use the Start menu
- ❖ Use Windows Explorer or My Computer to locate the program file
- ❖ Use the Run dialog box

The next three sections explain how to start a program from the Start menu, Explorer and the Run dialog box.

Starting a program from the Start menu

When you install a program, Windows usually puts an icon in the Programs menu. To start a program that has an icon in the Programs menu, follow these steps, which use the Windows Wordpad program as an example:

- 1 Click **Start**, then point to **Programs**.

Windows 98 Second Edition displays the Programs menu, which lists programs and program groups. If your program is listed, go to Step 3, otherwise, continue with Step 2.

- 2 Point to the program group, in this example, **Accessories**.

Windows 98 Second Edition displays the Accessories menu.

- 3 Click the program, in this example, **Wordpad**.

Windows 98 Second Edition opens Wordpad.

To close the program, click the **Close** button in the upper-right corner of the program's window.

Starting a program from Windows Explorer

If a program is not listed in the Programs menu, you can start it from Windows Explorer. Windows Explorer gives you a view of your computer's contents as a hierarchy or "tree." You can easily see the content of each drive and folder on your computer. To use this method, you need to know the file name and location of the program's executable file (this file ends with `.exe`).

The following example opens Wordpad using its file name, `wordpad.exe`.

- 1 Click **Start**, then point to **Programs**.

- 2 Click **Windows Explorer**.

- 3 In the left part of the window, under the C: icon, double-click the folder containing the program, in this case **Program Files**.

Windows Explorer shows the contents of the Program Files folder on the right side of the window. The left side of the window shows all the folders contained within the Program Files folder.

- 4 In the left part of the window, click **Accessories**.

Windows Explorer shows the contents of the **Accessories** folder on the right side of the window.

- 5 In the left part of the window, double-click **Wordpad**.

Windows opens Wordpad.

Starting a program from the Run dialog box

This example uses the Run command to start Wordpad:

- 1 Click **Start**, then click **Run**.

The Run dialog box appears.

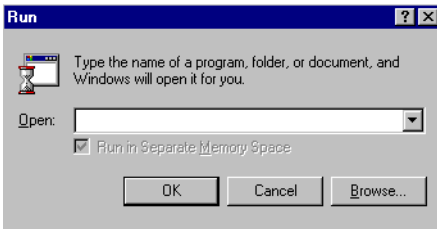

Run dialog box

- 2 In the Run dialog box:

- ❖ If you know the program's location, type the command line. For a program in the Windows folder, type just the program name. Otherwise type the full file path. For example, to access Wordpad, type:
c:\Program Files\Accessories\Wordpad, then click **OK**.

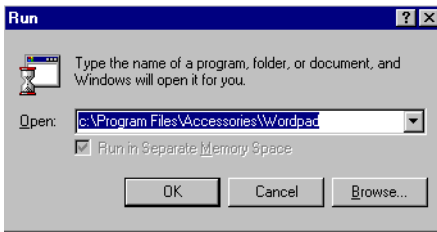

Entering a program name and path

- ❖ If you don't know the program's location, click **Browse...** In the Browse dialog box, enter the file name (for example *wordpad*) and select the drive to search. When Windows has found the file, click **Open**.



HINT: To run the same program again, click the arrow to the right of the text box and select the command line from the drop-down list.

Saving your work

Before you turn off the computer, save your work on the hard disk drive or a diskette. This is one of the most important rules of computing.



TECHNICAL NOTE: Save your data even when you are using the Standby command, in case the main battery discharges before you return to work.

Saving documents is quick and easy, so it is a good idea to get in the habit of saving frequently. That way, if you run into trouble, you won't lose many hours of work.

Many programs offer a feature that saves documents at regular intervals, such as every 15 minutes. Check your program's documentation to see whether it has an automatic save feature.

Saving files

- 1 On the **File** menu of your Windows program, click **Save**.

If you are working with a document that already has a file name, that's all there is to it. If you created a new document, your program displays a Save As dialog box.

Use this dialog box to specify where to store the document and to give it a file name.

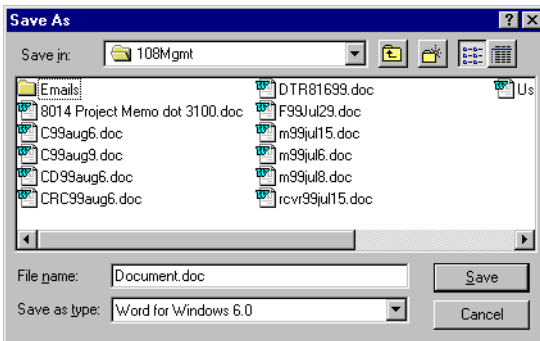

A sample Save As dialog box

- 2 Choose the drive and folder where you want your file to be stored.
- 3 Type a file name, then click **OK**.



HINT: To make another copy of the file you are currently working with, choose Save As from the File menu and give the new file a different name.

Windows 98 Second Edition supports file names of up to 255 characters, and the names can include spaces. However, some applications still require MS-DOS® file names.

File names

If you plan to share your files with a computer using a pre-Windows 95 version of Windows, the file name must be no more than eight characters long. Typically the file name also has an extension, consisting of a period and up to three additional characters.

You may use all the letters and numbers on the keyboard plus the following characters: `_`, `^`, `$`, `~`, `!`, `#`, `%`, `&`, `{`, `}`, `(`, `)`, `@` and `'`. MS-DOS file names are not case-sensitive and must not contain spaces.

Using a file extension

Most programs assign an extension to the file name that identifies the file as being created in the program with a particular format. For example, Microsoft Word saves files with a `.doc` extension. Any file name with an extension of `“.doc”` is assumed to be a Microsoft Word file. Creating your own extension is usually unwise, since the program is unlikely to recognize a strange extension and may refuse to handle your file correctly.

Printing your work

Make sure that the operating system is set up for your printer as described in [Using a printer on page 117](#).



HINT: You only need to set up the printer the first time you connect it. If you use more than one printer or are changing printers, you will need to set up Windows 98 Second Edition to run with the additional printer(s).

To print a file:

- 1 If your printer is not on, turn it on now.
- 2 Open the **File** menu of your Windows program and click **Print**.

The program displays a Print dialog box.

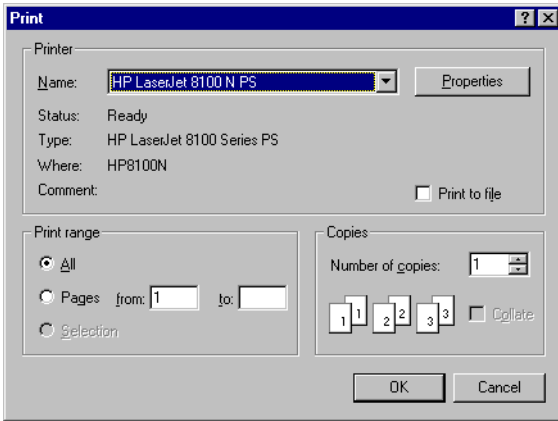

A sample Print dialog box

- 3 Specify the print parameters. For example, the range of pages and number of copies to print.
- 4 Click **OK** to print.

Using diskettes

This section provides information on inserting, removing and caring for your diskettes.

The 3.5-inch diskette drive lets you use either double-density (720 KB) or high-density (1.44 MB) diskettes for data transfer and storage.



Diskette drive

The diskette-in-use indicator glows while the drive is being accessed. However, you will find that the diskette/DVD light on the system indicator panel is easier to see while you are working.

The eject button releases the diskette from the drive.

Inserting and removing diskettes

To insert a diskette in the drive:

- 1 Hold the diskette so that the arrow on its upper surface points toward the drive.
- 2 Push the diskette gently into the drive.

When the diskette is in place, the eject button pops out.

To remove a diskette from the drive, press the eject button.



CAUTION: Never press the eject button or turn off the computer while the diskette/DVD light is glowing. Doing so could destroy data and damage the diskette or the drive.

Caring for diskettes

To protect the data stored on your diskettes:

- ❖ Store your diskettes in their boxes or other containers to protect them and keep them clean.
- ❖ Never slide back the protective metal cover.

- ❖ Avoid touching the magnetic surface of a diskette. Fingerprints can prevent the drive from reading the data stored on a diskette.
- ❖ Never twist or bend a diskette.
- ❖ Keep diskettes at room temperature and avoid exposing them to direct sunlight. Otherwise, data may be lost.
- ❖ Never place heavy objects on your diskettes.
- ❖ Never eat, smoke, or use erasers near diskettes. Foreign particles can damage the diskette's surface.
- ❖ Keep diskettes away from sources of magnetism, such as speakers and radios, since these can destroy data.
- ❖ If the diskette is dirty, clean it with a soft cloth moistened in water. Don't use cleaning fluids.

Using compact discs

The compact disc drive lets you read both DVD-ROM and CD-ROM discs.

This section provides information on inserting, removing and caring for your discs.

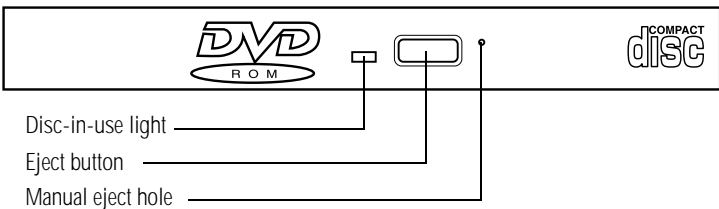

DVD-ROM drive

The disc-in-use light illuminates when the DVD-ROM drive is being accessed. However, you will find that the diskette/DVD light on the system indicator panel is easier to see while you are working.

Use the eject button to release the disc tray. This button requires power to operate.



CAUTION: Never press the eject button or turn off the computer while the diskette/DVD light is glowing. Doing so could damage the disc or the drive.

Be careful not to touch the lens or the area around it. Doing so could cause the drive to malfunction.

The manual eject hole provides access to the manual eject button, allowing you to manually open the disc tray when power to the computer and the drive is off.

To open the disc tray manually, insert a straightened paper clip or other narrow object through the manual eject button's access hole.



CAUTION: Never use a pencil to press the eject button. Pencil lead can break off inside the computer and damage it.

Inserting a disc



WARNING: Before playing an audio CD, turn the volume down. Playing the compact disc at maximum volume could damage your ears. To turn the volume down, use the Volume Control program (click Start, point to Programs, Accessories, Entertainment, and click Volume Control).

- 1** If the computer is turned on, press the eject button on the drive.

The disc tray partially opens.

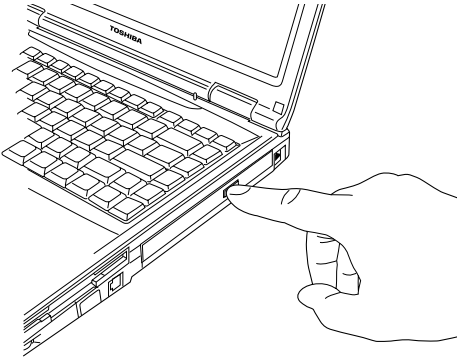

Opening the CD disc tray



CAUTION: To avoid damaging a disc or losing data, check that the diskette/DVD light is off before opening the disc tray.

- 2** Grasp the disc tray and pull it fully open.

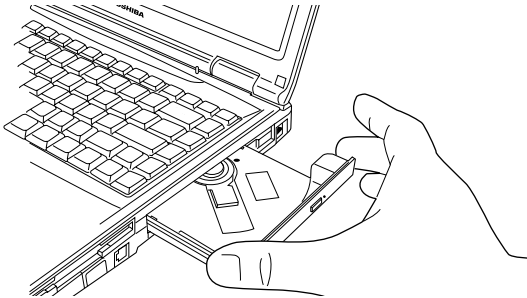

Pulling out the CD disc tray

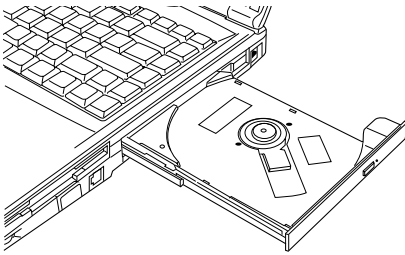

CD disc tray fully extended

- 3 Hold the disc by its edges and check that it is clean and free of dust.



CAUTION: Handle discs carefully. Avoid touching the surface of the disc. Grasp it by its center hole and edge. If you handle the disc incorrectly, you could lose data.

- 4 Carefully place the disc in the empty tray with its label facing up.



CAUTION: Be careful not to touch the drive's lens (located underneath the drive's spindle) or the area around it. Doing so could cause the drive to malfunction.

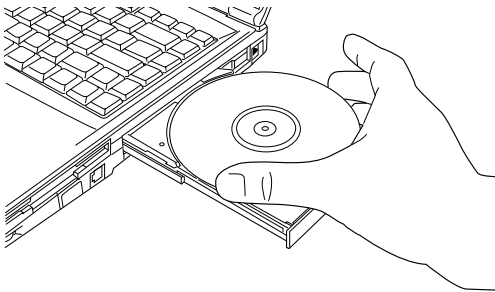

Setting a disc on the tray

- 5 Gently press the disc onto the center spindle until it locks into place.

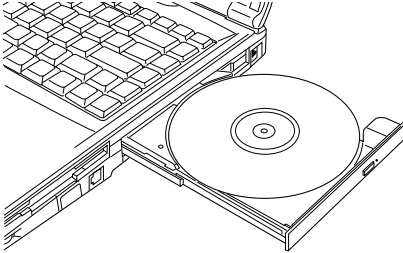

CD properly seated on the tray



CAUTION: Make sure the disc is properly positioned on the spindle. If you position the disc incorrectly, it can jam the disc tray.

- 6 Close the disc tray by pressing gently on the center of the tray until it clicks — indicating that it is locked.

An audio CD or a DVD will start playing automatically.

Removing a disc



CAUTION: Never press the eject button while the computer is accessing the drive. Wait for the diskette/DVD light on the system indicator panel to go out before you open the disc tray.

- 1 With the computer turned on, locate and press the eject button. The disc tray partially opens.



HINT: The computer must be on to use the eject button to open the disc tray. To remove a disc when the power is off (for example, if the main battery is completely discharged), use a slender object, such as a straightened paper clip, to press the manual eject button. You access this button through the small hole to the right of the eject button.

- 2 Grasp the sides of the disc tray and pull it fully open.
- 3 Remove the disc from the disc tray and place it in its protective cover.



CAUTION: If the disc is spinning when you open the disc tray, wait for the disc to stop before you remove it.

- 4 Close the disc tray by pressing gently on the center of the tray until it clicks — indicating that it is locked.

Caring for CDs and DVDs

- ❖ Store your discs in their original containers to protect them from scratches and keep them clean.
- ❖ Never bend a disc or place heavy objects on top of it.
- ❖ Hold a disc by its outside edge. Fingerprints on the surface of a compact disc can prevent the drive from reading the data properly.
- ❖ Avoid exposing discs to direct sunlight or extreme heat or cold.
- ❖ To clean a disc, wipe it from the center outwards (not in a circle) with a clean, dry cloth. If necessary, moisten the cloth with water or a neutral cleaner (not benzine or rubbing alcohol). Let the disc dry completely before inserting it in the tray.

Backing up your work

Your computer comes with a Configuration Builder CD that enables you to reinstall software that was preinstalled. This CD can be used to install or reinstall particular Toshiba applications, utilities, and drivers. However, you need to back up all the files you create in case something happens to your computer. If you have a network partition, you can hold copies of your files there.

Alternatively, you can back up your files to diskette one at a time as you are working on them.

To back up several files at one time, use Microsoft's Windows backup program preinstalled on the computer's hard disk.

Complete information on the backup program is in the online Help and your Windows documentation.



HINT: Backing up all the files on your hard disk takes a considerable amount of time and many diskettes. You may prefer to use a high-capacity backup system, such as an external tape drive.

Restoring your work

To restore information from your backup media to your hard disk, use the Restore page in the backup program. Look in the online Help or your operating system documentation for information on restoring files.



TECHNICAL NOTE: When restoring files, the backup program prompts you if you try to overwrite a file that already exists on the hard disk. Make sure the backup version is the one you want before overwriting the existing file.

Setting up for communications

To connect to the Internet, use an online service, or communicate across the telephone lines with another computer, you need:

- ❖ A modem (supplied with your computer)
- ❖ A telephone line
- ❖ A browser or communications program
- ❖ An Internet Service Provider (ISP) or an online service if you plan to use the Internet

Before you can use the modem, you must connect it to a standard voice-grade telephone line. See [Connecting the modem on page 44](#) for details.

Connecting your computer to a network

You can connect your computer to a network to increase its capabilities and functionality using one of its communication ports.

Accessing a network

To access a network:

- ❖ At the office, connect an Ethernet cable to the RJ45 jack on your computer. For specific information about connecting to the network, consult your network administrator.
- ❖ While you are at home or traveling, you need a dial-up connection. Ask your network administrator for the telephone number of the network.
- ❖ Wirelessly, you need an optional wireless networking PC Card or an optional Wi-Fi module. For more information about wireless networking, refer to your wireless network device documentation or your network administrator.

Setting up the connection

To set up an office connection, consult your network administrator for network settings and additional considerations.

To set up a dial-up connection, use the Dial-Up Networking Wizard:

- 1 Click **Start** and point to **Programs**.
- 2 Point to **Accessories**, then to **Communications**, and click **Dial-Up Networking**.
- 3 Enter the phone number of your network connection and let the program dial the number.

The computer connects to the network.

Setting up a wireless connection



NOTE: For systems with a PIII 750 MHz or PIII 800 MHz processor, the computer is wireless ready with a built-in antenna. Using this functionality requires an optional Wi-Fi module.

For systems with a PIII 850 Mhz processor, the wireless capability is integrated.

For information on how to set up a wireless connection, refer to your wireless networking device documentation or your network administrator.

Using SPANWorks™ 2000

The SPANWorks 2000 application offers enhanced meeting productivity between networked computers. You can do such things as transfer files between two computers, broadcast a slide presentation simultaneously to several machines, set up electronic

business cards, and send text messages to a few people or to everyone in your proximity.



NOTE: Before using SPANWorks, you must establish a network link between computers.

To access SPANWorks 2000:



- 1 Double-click the **SPANWorks** icon on the desktop.
- 2 Follow the instructions on your screen to set up a connection to the network.

Sending a fax

Your computer comes with RingCentral[®], an application that lets you use the computer's built-in modem to send faxes directly from your word-processing or spreadsheet program.



To start RingCentral, double-click its icon on the desktop. RingCentral opens and displays the RingCentral main window.



RingCentral main window

For more information about this program, refer to the RingCentral documentation provided with your computer.

Powering down the computer

When you power down the computer, you have three options to choose from: Shut down, Standby, and Hibernation.



TECHNICAL NOTES: Before using any of these methods to power down your computer, save your files and make sure the disk activity lights are off.

If you change your mind and decide to continue working after all, wait a few seconds before turning the computer on again.

Using Shut down

The Shut down command shuts the computer down completely. When you start up again, the computer runs a self-test and loads the operating system. You must open any programs and files you want to use.

Factors when choosing Shut down:

- ❖ No power is used while the computer is shut down. This is the most efficient mode if you will be away from your computer for an extended time.
- ❖ Restarting from Shut Down uses the most time and battery power.
- ❖ When starting up again, the system does not automatically open programs and files you were previously using.

To power down the computer using the Shut down command, click **Start, Shut Down**, select **Shut down**, then click **OK**.

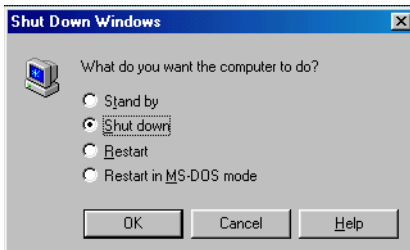

Shut Down Windows dialog box

The computer shuts down completely.

Shutting down more quickly

In addition to the method described above, you can shut down the computer by either pressing the power button or closing the display panel.

To use either of these methods, you first need to turn it on in Toshiba's Power Saver utility.

- 1 Open the **Start** menu, point to **Settings**, then click **Control Panel**.
- 2 In the Control Panel window, double-click the **Power Saver** icon.
- 3 In the Running on batteries area, click the **Details** button, then select the **System Power Mode** tab.

The following screen appears.

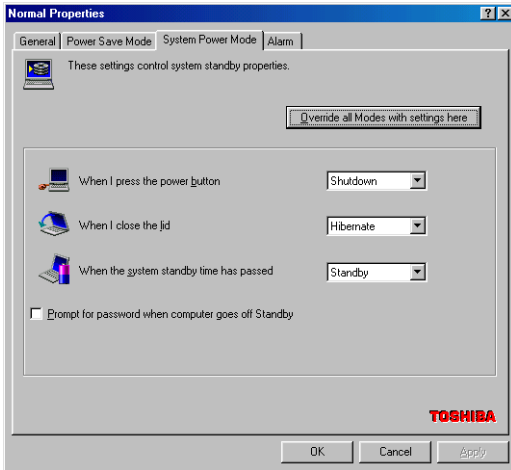

System power mode settings

- 4 Select **Shutdown** for the options you want.
 - ❖ **When I press the power button**
Set this option to Shutdown if you want the computer to shut down when you press the power button.
 - ❖ **When I close the lid**
Set this option to Shutdown if you want the computer to shut down when you close the display panel.
- 5 Click **Override all Modes with settings here**.
- 6 In the Set to range dialog box, do one of the following:
 - ❖ Click **DC only** if you want the settings to apply only when you are using battery power.
 - ❖ Click **All** if you want the settings to apply whether you are using battery power or outlet power.
- 7 Click **OK**.

- 8 Click **OK** again, then close the Control Panel.



NOTE: For more information about the Power Saver utility, see [Toshiba Power Saver utility on page 168](#).

Starting again after Shut down

To start the computer up again, press the power button until the on/off light changes to green.

If you shut down the computer by closing the display panel, you can start it again by opening the display panel.

Using Hibernation

Hibernation mode shuts the computer down completely, but it first saves the current state of the computer to the hard disk. Since Hibernation mode does not require power to maintain the saved information, the system settings are retained indefinitely. However, restoring information from the hard disk takes longer than restoring it from memory. When you start up again, the computer runs a self-test, loads the operating system, and then returns to the state in which you left it.

Factors to consider when choosing Hibernation:

- ❖ While in Hibernation mode, the computer uses no battery power
- ❖ Because the state of the system is held on the hard disk, no data is lost if the main battery discharges
- ❖ When starting up again, Hibernation uses less time and battery power than does Shut down
- ❖ Restarting from Hibernation uses a little more time and battery power to start up than restarting from Standby, because information is being retrieved from the hard disk rather than from memory

- ❖ When starting up again, the computer returns to the state in which you left it, including all open programs and files you were using

To configure the computer to use the Hibernation option:

- 1 Open the **Start** menu, point to **Settings**, then click **Control Panel**.



- 2 In the Control Panel window, double-click the **Power Saver** icon.
- 3 In the Running on batteries area, click the **Details** button, then select the **System Power Mode** tab.
- 4 Select **Hibernation** for the options you want.
 - ❖ **When I press the power button**
Set this option to Hibernation if you want the computer to go into Hibernation mode when you press the power button.
 - ❖ **When I close the lid**
Set this option to Hibernation if you want the computer to go into Hibernation mode when you close the display panel.
- 5 Click **Override all Modes with settings here**.
- 6 In the Set to range dialog box, do one of the following:
 - ❖ Click **DC only** if you want the settings to apply only when you are using battery power.
 - ❖ Click **All** if you want the settings to apply whether you are using battery power or outlet power.
- 7 Click **OK**.
- 8 Click **OK** again, then close the Control Panel.

The computer is now set to automatically go into Hibernation when your option settings occur.



NOTE: For more information about the Power Saver utility, see [Toshiba Power Saver utility on page 168](#).

Once the computer is configured, put the computer into Hibernation mode by either pressing the power button or closing the display panel, depending on the hibernation options taken.

Starting again from Hibernation mode

To start up the computer from Hibernation mode, press the power button until the on/off light turns green. The computer returns to the screen you were using.

If you put the computer in Hibernation mode by closing the display panel, you can start it again by opening the display panel.

Using Standby

The Standby command puts the computer into a power-saving state. Standby holds the current state of the computer in memory so that, when you restart the computer, you can continue working from where you left off.

Factors when choosing Standby:

- ❖ While in Standby mode, the computer uses some battery power. A fully charged main battery will last approximately eight hours in Standby mode.
- ❖ Restarting from Standby uses less time and battery power than restarting from Shut down or Hibernation.

- ❖ When starting up again, the computer returns to the state in which you left it, including all open programs and files you were using.
-



NOTE: If you power down using the Standby command and the main battery discharges fully, your information will be lost. Be sure to save your work first.

To power down the computer using the Standby command, click **Start, Shut Down**, select **Stand by**, then click **OK**.

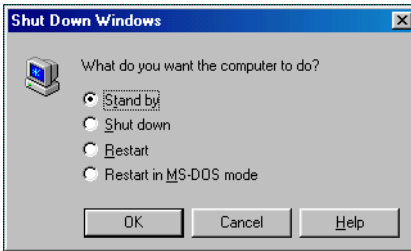

Shut Down Windows dialog box

The computer saves the status of all open programs and files, turns off the display, and goes into a low-power state. The on/off light blinks amber indicating the machine is in Standby mode.

Going into Standby mode more quickly

In addition to the method described above, you can put the computer into Standby mode by either pressing the power button or closing the display panel. You can also specify an amount of time after which the computer automatically goes into Standby mode.

To use any of these methods, you first need to enable them in Toshiba's Power Saver utility.

- 1 Open the **Start** menu, point to **Settings**, then click **Control Panel**.

- 2 In the Control Panel window, double-click the **Power Saver** icon.
- 3 In the Running on batteries area, click the **Details** button, then select the **System Power Mode** tab.
- 4 Select **Standby** for the options you want.
 - ❖ **When I press the power button**
Set this option to Standby if you want the computer to go into Standby mode when you press the power button.
 - ❖ **When I close the lid**
Set this option to Standby if you want the computer to go into Standby mode when you close the display panel.
 - ❖ **When the system standby time has passed**
Set this option to Standby if you want the computer to automatically go into Standby mode when you haven't used it for a specified amount of time. You can set the System standby time on the Power Save Mode tab.
- 5 Click **Override all Modes with settings here**.
- 6 In the Set to range dialog box, do one of the following:
 - ❖ Click **DC only** if you want the settings to apply only when you are using battery power.
 - ❖ Click **All** if you want the settings to apply whether you are using battery power or outlet power.
- 7 Click **OK**.
- 8 Click **OK** again, then close the Control Panel.



NOTE: For more information about the Power Saver utility, see [Toshiba Power Saver utility on page 168](#).

Starting again from Standby mode

To start up the computer from Standby mode, press the power button until the on/off light changes to green. The computer returns to the screen you were using.

If you put the computer in Standby mode by closing the display panel, you can start it again by opening the display panel.

Toshiba's online resources

Toshiba maintains a number of online sites to which you can connect. These sites provide information about Toshiba products, give help with technical questions and keep you up to date with future upgrades. For more information, see [Contacting Toshiba on page 213](#).

Chapter 4

Mobile Computing

This chapter covers all aspects of using your computer while traveling.

Toshiba's energy-saver design



Toshiba is a partner in the Environmental Protection Agency's (EPA) Energy Star Program and has designed this product to meet the Energy Star guidelines for energy efficiency.

Your computer enters a low-power standby state when it is not being used, thereby conserving energy and saving money in the process. It has a number of other features that enhance its energy efficiency.

Many of these energy-saving features have been set by Toshiba. We recommend you leave these features active, allowing your computer to operate at its maximum energy efficiency so you can use it for longer periods while traveling.

Running the computer on battery power



The computer contains a removable lithium ion (Li-ion) battery pack that provides power to the computer when it is not connected to an AC outlet. You can recharge the battery many times.

In addition to the removable lithium ion battery, the computer has an internal real-time clock (RTC) battery. This is a nickel metal hydride (NiMH) battery. The RTC battery powers the RTC memory, which stores your system configuration settings and the current time and date for up to a month while the computer is turned off.



TECHNICAL NOTE: For optimum DVD performance, always play DVDs while your computer is connected to AC power.

Maximizing battery life

A battery can be recharged many times. Gradually over time it will lose its ability to hold a charge. To maximize the life of your battery:

- ❖ Avoid leaving the computer plugged in and unused for more than a few hours. Overcharging the battery may shorten its life.
- ❖ If you are not going to use the computer for a long period of time, remove the battery.
- ❖ Alternate between battery packs if you have a spare.
- ❖ Make sure your computer is turned off, or in Hibernation mode, when you are replacing the battery.
- ❖ Store spare battery packs in a cool dry place out of direct sunlight.

Using additional battery packs

If you spend a lot of time traveling and need to work for many hours without an AC power source, you may want to carry additional charged battery packs with you. You can then replace a discharged battery and continue working.

Battery safety precautions

- ❖ Never try to disassemble a battery pack.
- ❖ Never overcharge or reverse charge a battery. Overcharging will shorten its life and reverse charging could destroy it, causing the release of toxic fumes.
- ❖ Avoid touching the metal terminals of the battery with another metal object. Short circuiting the battery will cause it to overheat and may cause permanent damage to the battery or the computer.
- ❖ Never incinerate a spent battery as this will cause it to explode, releasing toxic materials.
- ❖ If a battery is leaking or damaged, replace it immediately. Use protective gloves when handling a damaged battery.
- ❖ When you need to replace the battery, use an identical battery.

Charging batteries

The battery needs to be charged before you can use it to power the computer. You can charge the battery using your computer or you can use an optional battery charger.

Charging the battery

To charge the battery while it is in your computer, use the AC adapter to connect the computer to a live wall outlet. With the computer off, recharging the battery takes about three hours. The battery takes much longer to charge when the computer is on. The

battery does not charge while the computer is consuming full power.

The battery light:



- ❖ Glows amber while the battery is being charged.
- ❖ Glows green when the battery is fully charged.

The battery may not start charging immediately if:

- ❖ The battery is extremely hot or cold. To ensure that the battery charges to its full capacity, wait until it reaches room temperature (50 to 80 degrees Fahrenheit, 10 to 26 degrees Celsius).
- ❖ The battery is almost completely discharged. Leave the power connected and the battery should begin charging after a few minutes.



HINT: Once the battery is fully charged, we recommend you operate your computer on battery power until the battery discharges completely. Doing this extends the life of the battery and helps ensure accurate monitoring of battery capacity.

Charging the RTC battery

The RTC battery provides power for the internal real-time clock and calendar. During normal use, the battery keeps the RTC battery adequately charged. Occasionally, the RTC battery may lose its charge completely, especially if you have had the computer turned off for a long time.

To recharge the RTC battery, plug in the computer and leave it on for at least 24 hours.



TECHNICAL NOTE: It is seldom necessary to charge the RTC battery because it charges while the computer is on. However, if the RTC battery is low, the real-time clock and calendar become slow or stop working.

When Hibernation mode is enabled and the RTC battery is completely discharged, a warning prompts you to reset the real-time clock.

You can use the computer while the RTC battery is being charged, although the charging status of the RTC battery cannot be monitored.

Using a battery charger

You can purchase an optional battery charger that recharges lithium ion battery packs without requiring the use of your computer.



CAUTION: Avoid leaving batteries in the battery charger for more than a week at a time. Doing so may reduce the potential charge of the battery.

Use only battery chargers designed to work with your computer and its batteries.

You can order a Toshiba battery charger using the accessory information packaged with your computer, or through Toshiba's Web site (www.toshibaaccessories.com).

Monitoring battery power



The computer's battery light gives you an indication of the battery's current charge:

- ❖ No illumination means the battery has completely discharged and the AC adapter is not connected.

- ❖ Green means the battery is fully charged.
 - ❖ Amber means the battery is charging (AC adapter connected).
 - ❖ Flashing amber means the battery charge is low and it is time to recharge the battery or plug in the AC adapter.
-



HINT: Be careful not to confuse the battery light (🔋) with the on/off light (🖥️). When the on/off light flashes amber, it indicates that the system is suspended (using the Windows Standby command).

Determining remaining battery power



NOTE: Wait at least 16 seconds after turning on the computer before trying to monitor the remaining battery power. The computer needs this time to check the battery's remaining capacity and perform its calculations.

- 1** Click **Start**, point to **Settings**, and then click **Control Panel**.
- 2** Double-click the **Power Saver** icon.
- 3** Choose the Power meter tab to show the current charge state of the battery.

The value displays as a percentage of remaining battery charge.



TECHNICAL NOTE: The computer drains battery power faster at low temperatures. Check your remaining charge frequently if you're working in temperatures below 50 degrees Fahrenheit.

The computer calculates the remaining battery charge based on your current rate of power use and other factors such as the age of the battery.

What to do when the battery runs low

When the battery runs low you can:

- ❖ Plug the computer into an external power source and recharge the battery.
- ❖ Put the computer in Hibernation mode and replace the battery with a charged spare.
- ❖ Save your work and turn off the computer.

If you don't manage to do any of these things before the battery completely runs out of power, the computer automatically enters Standby mode and turns itself off. Standby mode keeps track of where you were so, when you turn on the power again, you can continue where you left off.

The computer stores information on what you were doing until the battery runs out of power. If you have Hibernation mode enabled (the default), the computer copies the details of your open programs and files to the hard disk before shutting down.

Conserving battery power

How long a fully charged battery pack lasts when you are using the computer depends on a number of factors, such as:

- ❖ How the computer is configured
- ❖ How much you use the display panel instead of an external monitor
- ❖ How much you use the hard disk and other drives
- ❖ Whether you use any optional devices to which the battery supplies power
- ❖ Where you are working — since operating time decreases at low temperatures

Toshiba's power-saving options greatly increase the length of time you can use the computer before you need to recharge the battery.

Toshiba has combined these options into three preset power usage modes:

- ❖ **Long Life** — This option provides you with the most efficient power usage, prolonging the time you can use your battery before you have to recharge or replace it.
- ❖ **Normal** — This option provides average power usage, where the battery will need to be replaced or recharged sooner than the Long Life option.
- ❖ **High Power** — This option uses optimum power to run your computer, therefore, you will need to replace or recharge the battery more often than with the Long Life and Normal power usage options.

The procedure for setting up your system to run more efficiently and prolong the time you can use a battery involves selecting options from two utilities:

- ❖ **Toshiba Hardware Setup**
- ❖ **Power Saver Utility**

Using Hardware Setup

The first stage is to select the Toshiba Hardware Setup option:

- 1** Click **Start**, point to **Control Panel**, then double-click **Toshiba Hardware Setup**.

The Toshiba Hardware Setup window appears.

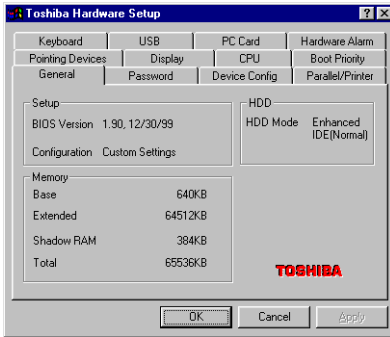

Toshiba Hardware Setup window

- 2 Click the **CPU** tab. Make sure that the **Dynamically Switchable** option, located in the Dynamic CPU Frequency mode section of the window, is selected.
- 3 Click **OK**.

Using the Power Saver Utility

The second stage is to set the Power Saver option:

- 1 Click **Start**, point to **Settings**, then click **Control Panel**.
- 2 Double-click the **Power Saver** icon.

The Power Saver Properties window appears, with the Power Save Modes tab displayed.

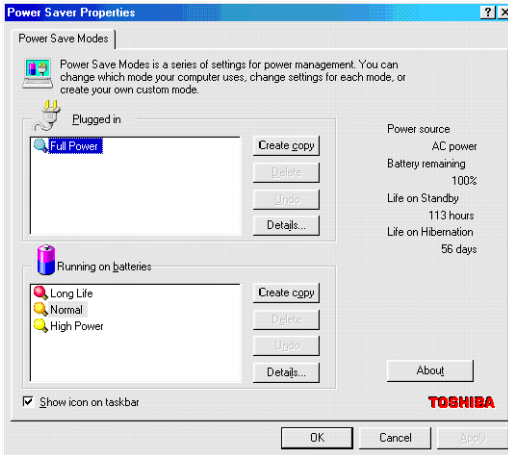

Power Saver Properties window

- 3 Highlight the **Long Life** mode in the Running on batteries section of the window.
- 4 Click **OK**.

Using a hot key to select the power usage mode

- 1 Press Fn and F2 simultaneously to display the power usage pop-up window.

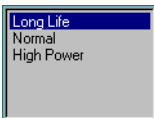

Power usage pop-up window

- 2 While continuing to press Fn, press F2 until you select the desired power usage mode.
- 3 Release the Fn key.

You're now in the selected mode.

Turning off the display automatically

To save power, it's a good idea to set the display to turn off automatically when you're not using the computer. You can do this several ways:

- ❖ Use the Windows Display Properties to enable a blank screen saver.
- ❖ Use the Windows Power Saver Properties to turn off the LCD panel after a certain amount of time has passed.

Enabling the screen saver

- 1 Click **Start**, point to **Settings**, then click **Control Panel**.
- 2 Double-click **Display**, and click the **Screen Saver** tab.

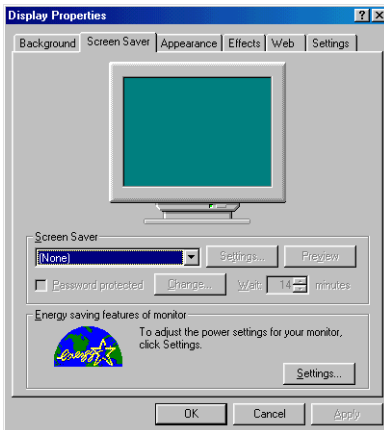

Screen Saver tab of the Display Properties dialog box

- 3 In the section labeled **Screen Saver**, select **Blank Screen**.
- 4 In the Wait window, click the up and down buttons to set the number of minutes before the display turns off automatically.
- 5 Click **OK** to save your changes and exit the **Display Properties** dialog box.

Using battery alarms

You can configure the computer to warn you when the battery is running low. There are two alarms available:

❖ **Low Battery alarm**

The Low Battery alarm gives you an audible warning when the computer's battery has about 10 percent of its charge remaining. You can set the volume (off - low - medium - high) for the low battery alarm.

❖ **Critical Battery alarm**

The Critical Battery alarm notifies you when the computer's battery has about five minutes remaining. You can choose whether the Critical Battery alarm gives you an audible and/or a visible warning.

To modify the default settings in the Power utility, click **Start**, point to **Settings**, and click **Control Panel**. Double-click the **Power Saver** icon, then click the **Alarms** tab.

Changing the main battery



When the battery runs out of power:

- ❖ If AC power is available, run the computer from the AC source while the battery charges, or shut down the computer and allow the battery to recharge.
- ❖ If you have charged a spare battery, change the battery.



CAUTION: Handle battery packs carefully to prevent damage to the casing. Avoid dropping the battery or mishandling it. Also, be careful not to short-circuit the battery terminals.

Removing the battery from the computer

- 1 Save your work.
-  2 Shut down the computer.
- 3 Remove all cables connected to the computer.
- 4 Close the display panel and turn the computer upside down.
-  5 Carefully slide the battery lock to one side to release the battery module.

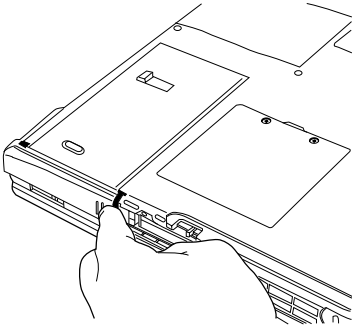

Releasing the battery lock

-  6 Slide the battery module out of the battery compartment (about 3/4 inch) until it stops.

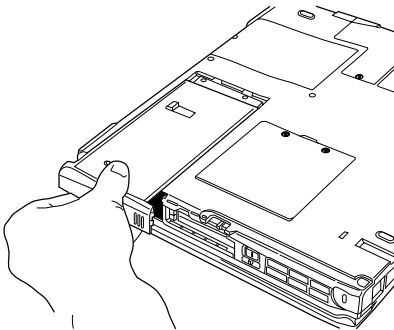

Pulling out the battery

- 7 Gently lift the battery module out of the battery compartment and remove it from the computer.

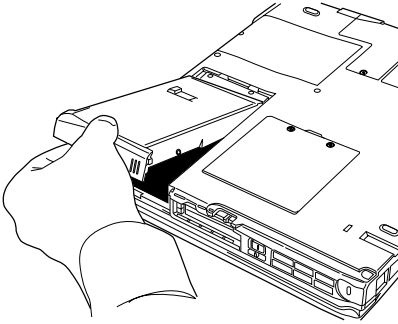

Removing the battery



WARNING: If the battery is leaking or its case is cracked, wear protective gloves. Discard the battery immediately, following the advice in [Disposing of used batteries safely on page 105](#).

Inserting a charged battery

- 1 Wipe the terminals of the charged battery with a clean cloth to ensure a good connection.
- 2  Slide the battery lock to the unlocked position (toward the front of the computer).
- 3 Without using force, place the battery module in the battery compartment.



HINT: When properly seated, the battery cover is flush with the bottom of the computer.

- 4  Using light pressure, slide the battery module toward the contacts in the battery compartment and hold it in place.

-
-  **5** Slide the battery lock to the locked position.
-



CAUTION: Failure to lock the battery module into position can result in the battery falling out of the computer.

- 6** Turn the computer right side up.
7 Reconnect any cables.



- 8** Turn on the computer.

Disposing of used batteries safely

You can recharge a battery pack many times, so it should last for years. When the battery pack needs replacing, the battery light flashes amber shortly after you have fully recharged the battery.

You must also discard a battery pack if it becomes damaged.



WARNING: The battery can explode if not properly handled or disposed of. Putting spent batteries in the trash is not only irresponsible, it may also be illegal.

Dispose of the battery as required by local ordinances or regulations. Use only batteries recommended by Toshiba as replacements.

Your company probably has a procedure for dealing with old batteries. If not, the materials that came with your computer may include an insert regarding the disposal of batteries. Otherwise, check with your local government for information on where to recycle or dispose of old batteries.

Traveling tips

The environmental precautions listed in [Selecting a place to work on page 40](#), also apply while travelling.

- ❖ Never leave your computer on a sunny ledge or in a place where it could get wet or covered in dust.
- ❖ Always travel with the computer in a carrying case. Toshiba offers a choice of carrying cases for the computer. They all provide plenty of extra space for manuals, power cables, compact discs and diskettes. Contact your authorized Toshiba representative for more information.



TECHNICAL NOTE: When traveling by air, you may be required to pass your notebook through airport security equipment. The X-ray equipment will not harm your computer.

Chapter 5

Expansion Options

Your computer is designed to work in the office as well as on the road. This chapter explains how to set up the various optional devices so that your notebook can provide all the convenience of a traditional desktop computer.

Devices for office computing

By connecting optional devices such as an external monitor, a full-size keyboard and a mouse, you can work with your notebook as if it were a standard office computer. An optional port replicator allows you to connect your computer quickly and easily to all the additional equipment you use at the office.

You can connect any of the following optional devices:

- ❖ Expansion memory modules
- ❖ Standard 101-key keyboard
- ❖ Traditional mouse or trackball
- ❖ Printer
- ❖ External monitor

- ❖ PC Cards
- ❖ Expansion devices

Some are Toshiba devices, others are standard computer components. The devices manufactured by Toshiba can be purchased through Toshiba's Web site www.toshibaaccessories.com, or through the accessories information packaged with your computer.

Connecting external (optional) devices



You can connect an external PS/2 keyboard or a PS/2 mouse through the PS/2 port on the back of your computer. If you use an optional Y-cable, you can connect both a mouse and a keyboard to the port.



You can connect a serial mouse through the serial port on the back of your computer.

You can connect a USB keyboard and mouse to the USB ports on the left side of your computer.



You can connect a local parallel printer through the parallel port on the left side of your computer.



You can connect an external monitor through the video-out port on the back of your computer.

You can connect an expansion device through the expansion port on the back of your computer.

Installing additional memory (optional)

Your computer comes with enough memory to run most popular applications. However, you may want to increase the computer's memory if you use complex software or process large amounts of data.

With additional memory, the computer:

- ❖ Can run more programs and open more documents at the same time
- ❖ Will run your Windows operating system and Windows applications faster

You can expand the memory on your computer to 512 MB.

Memory module sizes

Additional memory is easy to install. Memory modules come in the following sizes:

- ❖ 64 MB PC100 SDRAM
- ❖ 128 MB PC100 SDRAM
- ❖ 256 MB PC100 SDRAM

Normally Satellite Pro computers are supplied with a single 128 MB memory module. You can increase memory to 384 MB by fitting a second memory module. For the maximum of 512 MB, you need to replace the supplied 128 MB module with a 256 MB module.

<i>1st module</i>	<i>2nd module</i>	<i>Total memory</i>
128 MB	-	128 MB
128 MB	64 MB	192 MB
128 MB	128 MB	256 MB
128 MB	256 MB	384 MB
256 MB	256 MB	512 MB

Installing a memory module

The memory modules fit into the memory expansion slot on the underside of the computer. You need a standard Phillips no. 1 screwdriver to remove the expansion memory slot cover.

If you are adding memory after you have started using the computer, shut down the operating system, close the display panel and remove any cables.



CAUTION: Installing a memory module with the computer's power on may damage the computer, the memory module or both.

- 1 Turn the computer over and locate the expansion memory slot cover. If you need help, see [Underside on page 33](#).



- 2 Using a standard Phillips no. 1 screwdriver, remove the two screws that secure the expansion memory slot cover, then remove the cover.

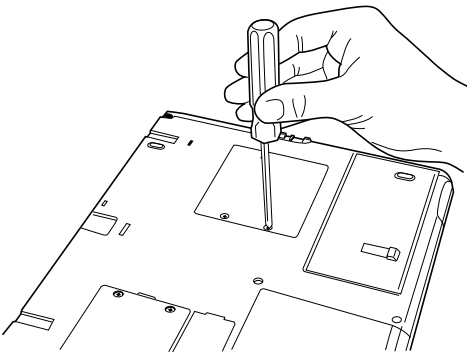

Removing the expansion memory slot cover

- 3 Put the screws in a safe place so that you can retrieve them later.



CAUTION: Static electricity can damage the memory module. Before you handle the module, touch a grounded metal surface to discharge any static electricity you may have built up.

To avoid damaging the memory module, be careful not to touch its pin connector (on the side you insert into the computer.)

- 4** Remove the memory module from its antistatic packaging.
- 5** Place the memory module in the memory expansion slot at a 45-degree angle, aligning the memory module's connector with the memory expansion connector.

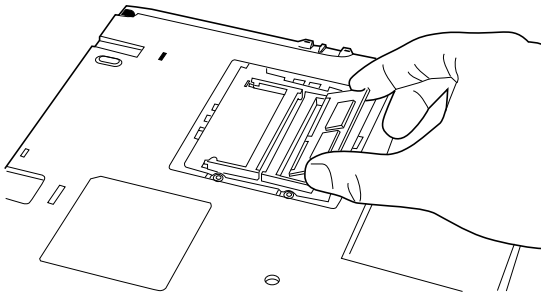

Placing the memory module into the expansion memory connector



HINT: The memory module only fits one way.

- 6 Gently press the free edge of the memory module into the slot until the latches snap, holding the memory module in place.

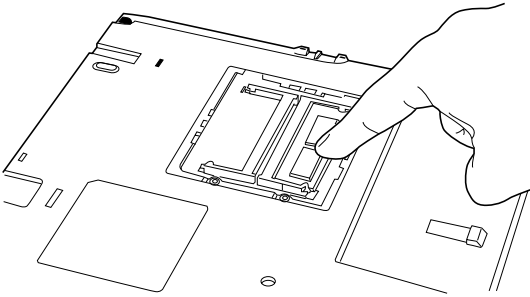

Seating the memory module

- 7 Replace the expansion memory slot cover and secure it with the screws you removed earlier
- 8 Turn the computer over and reconnect any cables you removed.

When you turn on the computer, it automatically recognizes the additional memory. If the computer does not recognize the memory, shut down the computer, remove the memory slot cover and make sure the memory modules are seated properly, as described in step 6.

Removing a memory module

The memory module is accessed from the underside of the computer. You need a standard Phillips no. 1 screwdriver to remove the expansion memory slot cover.

To remove a memory module:

- 1 Shut down the operating system, close the display panel and remove any cables.
- 2 Turn the computer over and locate the expansion memory slot cover. If you need help, see [Underside on page 33](#).



- 3 Using a standard Phillips no. 1 screwdriver, remove the two screws that secure the expansion memory slot cover, then remove the cover. Put the screws where you can retrieve them later.
- 4 Gently press the latches on both sides of the memory module to release the module from the connector.

The memory module pops partially out of the slot.

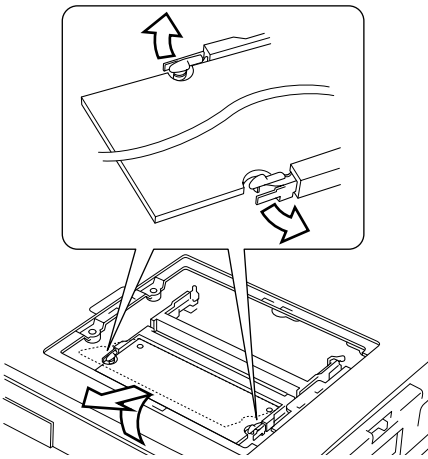

Pulling the latches away from the memory module

- 5 Carefully remove the module from the slot and place it in antistatic packaging.



NOTE: Avoid touching the connectors on the memory module or on the computer. Grease or dust on the connectors can cause memory access problems.

- 6 Fit a new memory module if required, following steps 4 through 6 of [Installing a memory module on page 110](#).
- 7 Replace the expansion memory slot cover and secure it with the screws you removed earlier.

- 8 Turn the computer over.
- 9 Reconnect the cables you removed earlier and turn on any peripheral devices that are connected to the computer.
- 10 Press the power button to start the computer.

When you turn on your computer, it automatically recognizes the new memory configuration.

Using an external keyboard

If you prefer to use a full-size keyboard, you can attach one to your computer. The computer's PS/2 mouse/keyboard port supports any PS/2-compatible keyboard.



CAUTION: Make sure the computer is off before you attach the external keyboard. Connecting an external keyboard with the computer's power on can damage the external keyboard, the computer, or both.

You can only connect one PS/2 device at a time, unless you use an optional Y-cable. Connecting a Y-cable to the computer's PS/2 port allows you to connect a PS/2-compatible mouse and a PS/2-compatible keyboard simultaneously.

Alternatively, you can connect a USB keyboard and mouse to the USB ports.

Making your external keyboard emulate the Fn key

An external keyboard doesn't have the Fn key contained on the computer's built-in keyboard. If you use the computer's hot keys or have set up key combinations in Fn-esse[®], you'll probably miss these features when using an external keyboard. Don't worry: you can use a key combination on the external keyboard to emulate the Fn key. You can set up this key combination through the Toshiba Hardware Setup option on the Control Panel.

For more information about Fn-esse and Toshiba Hardware Setup see [Toshiba Utilities on page 159](#).

Using a mouse

You may want to use a mouse instead of the computer's built-in pointing device, the AccuPoint II. You can use a PS/2-compatible mouse, a serial mouse or a USB mouse.



TECHNICAL NOTE: A serial mouse disables the AccuPoint II. With a PS/2 mouse, you can choose to have the AccuPoint II active at the same time.

Connecting a serial mouse



To connect a serial mouse, connect the mouse cable to the serial port at the back of the computer. Once connected, the mouse is ready to use.

Refer to your mouse documentation for configuration information.

Connecting a USB mouse

To connect a USB mouse, connect the mouse cable to the USB port on the computer. Once connected, the mouse is ready to use.

Connecting a PS/2 mouse



CAUTION: Make sure the computer is off before you attach the mouse. Connecting a PS/2 mouse with the computer's power on can damage the mouse, the computer, or both.

If you are connecting a mouse after you have started using the computer, begin at step 1. Otherwise go to step 2.

- 1 Click **Start**, **Shut Down**, select **Shut down**, then click **OK**.

Windows shuts off the computer.



- 2 Attach the PS/2 mouse cable to the PS/2 port on the computer.
-



HINT: Using an optional Y-cable allows you to connect a PS/2 mouse and a PS/2 keyboard to the PS/2 port simultaneously.

- 3 Refer to your mouse documentation for configuration information.

If you want to use both the PS/2 mouse and the AccuPoint II, you need to set this up when you have loaded the operating system.

Using a PS/2 mouse simultaneously with AccuPoint II

To configure the PS/2 mouse to work with the AccuPoint II:

- 1 Click **Start**, **Settings**, then **Control Panel**.
Windows displays the Control Panel window.
- 2 Click the **Toshiba Hardware Setup** icon.
- 3 Select the **Pointing Devices** tab.
- 4 Under Pointing Devices Options, select one of the following:
 - ❖ Auto-selected — configures the PS/2 mouse to work when it is connected at power on, or the AccuPoint II to work otherwise. Auto-selected is normally the default option.
 - ❖ Simultaneous — configures both the AccuPoint II mouse and PS/2 mouse to work with the computer at the same

time. You must reboot the computer for the settings to take effect.



HINT: When Auto-selected is the default, the computer can't detect a PS/2 mouse if you connect it after booting the computer.

This can be changed in Toshiba Hardware Setup.

5 Click **OK**.

A message appears stating “The changes will take effect next time the machine is rebooted. Reboot the machine now?”

6 Click **Yes**.

The computer reboots, and the PS/2 mouse is activated.

Using a printer

Before you can connect a printer, you must determine whether it requires a parallel, serial, infrared, or a USB interface. Check the printer's documentation. If you can configure the printer as either a serial or a parallel device, set it up for parallel operation.

You also need a suitable printer cable, which may have been provided with your printer. If not, your company may keep a stock of cables. Otherwise, you can purchase one from a computer or electronics store.



TECHNICAL NOTE: If your printer is ECP- or IEEE-compliant, make sure your printer cable is an IEEE 1284 cable.

Connecting a parallel printer

Parallel printers are the most common type of printer in use today. These instructions assume you have a parallel printer.

- 1 If you have been using the computer, turn it off.
- 2 If the computer is connected to an AC power source, disconnect the AC adapter.



CAUTION: Never connect the printer cable while the computer is on. Doing so may damage the printer, the computer, or both.



- 3 Connect the printer cable to the printer and to the computer's parallel port. Use the printer cable illustration as a connection guide.

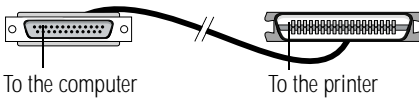

Identifying the ends of a parallel printer cable

- 4 Plug the printer's power cable into a live electrical outlet.
- 5 See your printer documentation for additional configuration steps.

For more information on getting your printer to print, see [Printing your work on page 69](#).

Setting up your printer

Setting up a printer involves selecting a printer driver. This special program acts as a translator that turns your document into a form the printer can understand.

If you are using any non-Windows programs, you need to set up a printer driver for each of those programs. Refer to your program's documentation for more information.

To set up a printer with the Add Printer Wizard:

- 1 Click **Start**, then point to **Settings**, and click **Printers**.

Windows opens the Printers window.

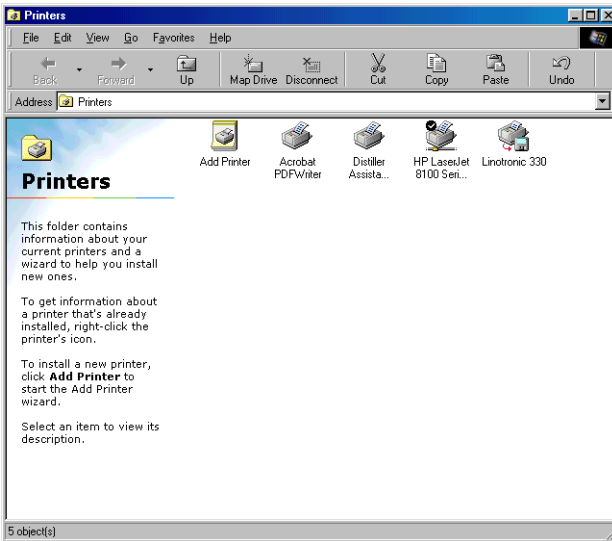

Printer window

- 2 Double-click **Add Printer**.

The Add Printer Wizard appears.

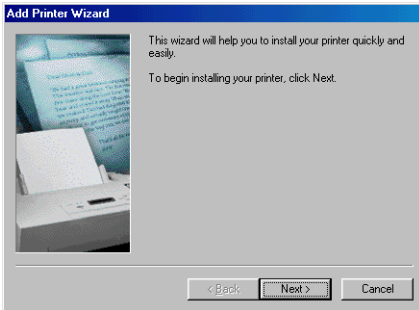

Add Printer Wizard

3 Click **Next**.

The Add Printer Wizard asks you to select your printer.



TECHNICAL NOTE: If your printer is Plug and Play, Windows 98 Second Edition recognizes it automatically. You can ignore the remainder of this section. See your printer manual.

4 If the printer you are setting up:

- ❖ Is not connected to a network, select **Local printer**.
- ❖ Is connected to a network, select **Network printer**.

5 Click **Next**.

The Add Printer Wizard prompts you to select your printer.

6 From the list of manufacturers and printers, select your printer, then click **Next**.

The Add Printer Wizard prompts you for the printer port.

7 Select the port settings according to the instructions in your printer's documentation and the port to which your printer is connected, then click **Next**.

The Add Printer Wizard prompts you to enter a “friendly” printer name.

- 8 Enter a name for your printer.



HINT: If you are using more than one printer, make sure the name is descriptive enough to help you tell the difference.

- 9 If you want this printer to be:
- ❖ The default printer for Windows 98 Second Edition, click **Yes**.
 - ❖ Available when specifically requested, click **No**.

- 10 Click **Next**.

Windows 98 Second Edition prompts you to print a test page.

- 11 If your printer is connected and turned on, click **Finish** to print a test page.

To complete the setup procedure without printing a test page, click **No**, then click **Finish**.

You are now ready to print.

- 12 If you requested a test page, click **OK** to print.

Depending on your program, you may see various messages indicating the status of your print job.



TECHNICAL NOTE: Some printers require a specific installation process. In this case, the Windows 98 Second Edition Add Printer Wizard will display an error message. If this happens, refer to your printer installation guide for further instructions.

Using an external monitor

Your computer comes with a built-in LCD display, but you can also connect other external display devices to one of two available video ports:

- ❖ A television via the television jack.
-



TECHNICAL NOTE: In Windows 98 Second Edition, you don't need an Internet connection to watch cable or broadcast TV, but you must purchase a compatible TV tuner card.

- ❖ A video display device, such as a video projection unit, via the television jack.
- ❖ An external SVGA monitor via the video-out port.

Before connecting your television, video projector, monitor or other display device, configure your computer for the type of device you're connecting. To do this, refer to your operating system documentation.

Connecting the display device

If you're connecting a television or other video display device to the computer's television jack, refer to the following section for guidelines on choosing a video cable, then refer to [Connecting a device to the television jack on page 123](#).

If you're connecting an SVGA monitor, skip to [Connecting an external monitor on page 123](#).

Selecting video cables

To connect a device to the television jack, you need a video cable. For the best video quality, always use a properly shielded cable.



HINT: Toshiba recommends using a cable no longer than 20 feet (approximately 6 meters).

Using a poor quality cable may result in a dull or fuzzy picture, poor color, ghosting, video noise, or loss of video.

Connecting a device to the television jack

- 1 Connect one end of the video cable to the external video device.

Refer to the documentation provided with the device for the location of its television signal-in jack.



- 2 Connect the other end of the video cable to the television jack on the computer.
- 3 Connect the external device's power cable to a live electrical outlet.
- 4 Turn on the external video device.
- 5 Set the display mode by pressing Fn + F5, or by changing the Display Properties settings. For more information, see [Directing the display output when you turn on the computer on page 124](#).

Connecting an external monitor

You can easily attach an external monitor to your computer if you need a larger screen. To do this:

- 1 Connect one end of the external monitor's video cable to the video-in port.

Refer to the documentation provided with the monitor for the location of its video-in port.



- 2** Connect the other end of the video cable to the video-out port on the computer.
- 3** Connect the monitor's power cable to a live electrical outlet.
- 4** Turn on the external monitor.
- 5** Set the display mode by pressing Fn + F5, or by changing the Display Properties settings. For more information, see the next section.

Directing the display output when you turn on the computer

Once you've connected an external display device, you can choose to use the built-in display panel only, the external device only, or both simultaneously. The quickest way to change the display output settings is to use the display hot key (Fn + F5):

- 1** Press Fn and F5 simultaneously.
- 2** While holding down Fn, press F5 repeatedly until the setting you want takes effect.

This hot key cycles through the settings in the following order:

- ❖ Built-in display only
- ❖ Built-in display and external monitor simultaneously
- ❖ External monitor only
- ❖ Built-in display and TV (or other external video device) simultaneously (only when in dual controller mode)
- ❖ TV (or other external video device) only

3 Release the Fn key.



TECHNICAL NOTE: You can also change these settings using the Display Properties Box.

Set the option for the video controller by clicking Start, pointing to Settings, Control Panel and clicking Display Properties. Choose the Settings tab, click the Advanced Properties button and select S3 DuoView+.

For more information on switching the display output, see [Display modes on page 221](#).

Adjusting the quality of the external display

To obtain the best picture quality from your television (or other video display device), you may need to adjust the video settings. See the video device documentation for additional configuration steps.



TECHNICAL NOTE: In order to use one of the simultaneous modes, you must set the resolution of the internal display panel to match the resolution of the external display device.

Video limitations

Keep in mind that the quality of the display will be limited to the capabilities of the external video device.

Since most televisions and video projectors overscan by 15 to 20 percent, some of the desktop will be outside the viewing area. You can view the edge of the desktop by scrolling to it.

Using PC Cards

PC Cards are credit-card sized expansion cards that greatly increase the capabilities of your computer.

Some PC Cards combine several functions. Multifunction cards are handy if you want to get the most out of your PC Card slot.

Your computer comes with two stacked PC Card slots on the left side and it supports two Type II PC Cards, or one Type III PC Card.

Most PC Cards conform to the PCMCIA (Personal Computer Memory Card International Association) standard.



TECHNICAL NOTE: For PCMCIA-compatible PC Cards, check the package to make sure they conform to the PCMCIA 2.1 standard (or later). Other cards may work with your computer, but they are likely to be much more difficult to set up and use.

Inserting a PC Card

Before you insert your PC Card, read through the documentation that comes with the card to see if it has any special requirements.



CAUTION: Your computer came with all the Card and Socket Services programs you need. Even if your PC Card comes with its own version of Card and Socket Services, you should use the files provided on your computer.

To insert a PC Card:

- 1 Locate the PC Card slot on the left side of the computer.
- 2  If the PC Card slots are locked, unlock them by sliding the PC Card lock into the unlocked position.



- 3 Position the PC Card device in a PC Card slot.

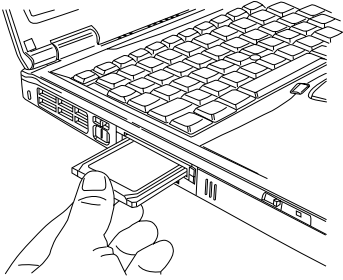

Inserting a PC Card

If you have a Type III card, insert it into the lower part of the slot. If you have a Type I or Type II card, insert it into either the upper or lower part of the slot.

- 4 When the card is almost all the way into the slot, push firmly, but gently, to ensure a firm connection with the computer.

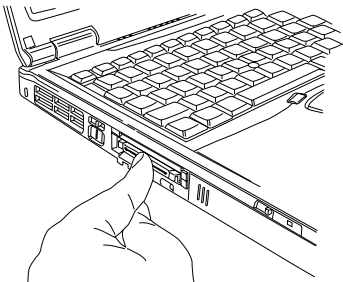

Inserting a PC Card



CAUTION: Forcing the card into the PC Card slot can damage the card.

-  **5** To lock your PC cards in the slots, slide the PC Card lock to the locked position.

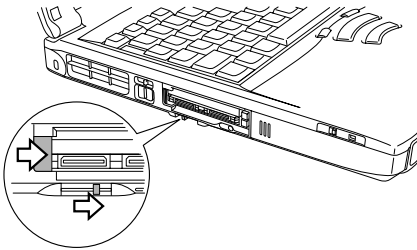

Locking the PC Card slots



TECHNICAL NOTE: Securing the PC Cards in place to deter theft requires the use of a PORT-Noteworthy Cable Lock.

For more information on the PORT-Noteworthy Cable Lock, see [Using a computer lock on page 57](#).

Removing a PC Card

- 1** Make sure that the PC Card is not in use. Click the **PC Card** icon in the system tray.

- 2** Click **Stop xxx**, where xxx is the identifier for your PC card.

Windows displays a message indicating that you may safely remove the card.

-  **3** If the PC Card slots are locked, unlock them by sliding the PC Card lock into the unlocked position.

- 4** Locate the PC Card eject button that corresponds to the slot in which your PC Card is installed.

The top button releases a card in the upper slot. The bottom button releases a card in the lower slot.

- 5** Push the PC Card eject button next to the PC Card.

The PC Card eject button pops out further.

- 6 Push the PC Card eject button again.
The PC Card ejects slightly from the slot.
- 7 Grasp the edges of the PC Card and pull it out of the slot.

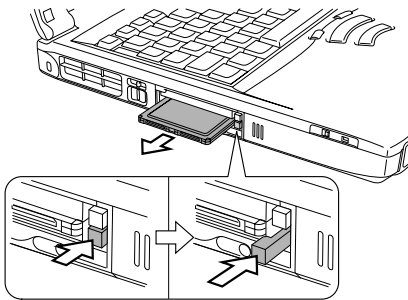

Removing a PC Card

-  8 To lock any remaining PC cards, slide the PC Card lock to the locked position.

Setting up your PC Card for your computer

Some PC Cards are ready to use as soon as you install them. Others, such as hard disk cards, network cards and SCSI adapters, may need to be set up to work with your computer. To set up your PC Card, refer to the documentation that came with the card or refer to your operating system manual or online help.

Hot swapping PC Cards

One of the great things about PC Cards is that you can replace one PC Card with another while the computer is on. This is called “hot swapping.”

Hot swapping precautions

Although you can insert a PC Card at any time, remember not to remove a card while it is in use. Otherwise, you could lose valuable information.

For example:

- ❖ Never remove a hard disk card while the system is accessing the card.
 - ❖ Never remove a network card while you are connected to the network.
 - ❖ Never remove a SCSI card while any of the SCSI devices connected to it are operating.
-



DEFINITION: SCSI is an acronym for Small Computer Systems Interface. A single SCSI PC Card enables you to connect several SCSI devices to your computer at the same time.

Before removing a PC Card, stop it by clicking the **PC Card** (PCMCIA) icon on the taskbar (see [Removing a PC Card on page 128](#)).

Using an expansion device



The expansion port allows you to connect your computer to an expansion device, which is an excellent investment if you're using your computer both in and out of the office.

When you return to your desk, you probably want to connect to your network, print reports from your computer, or use a mouse instead of the AccuPoint II. Connecting cables for each of these devices every time you return to the office is time-consuming and inconvenient. With an expansion device, you can leave external devices connected while you are using your computer away from your desk. When you return, you can quickly connect your computer and have immediate access to all the devices.

For more information, see the accessories information packaged with your computer, or visit the Web site:

www.toshibaaccessories.com.

Chapter 6

Enhancing Productivity

In this chapter, you will explore additional features of your notebook computer.

Exploring the desktop

The desktop is the launching pad for everything you can do in Windows 98 Second Edition. You use its features to start programs, find documents, set up system components, and perform most other computing tasks.



HINT: The illustrated examples in this guide may appear slightly different from the screens displayed by your system. However, the differences are not significant and do not indicate any change in the functionality of your system.

Finding your way around the desktop

Common desktop features include icons, the Start button, and the taskbar.

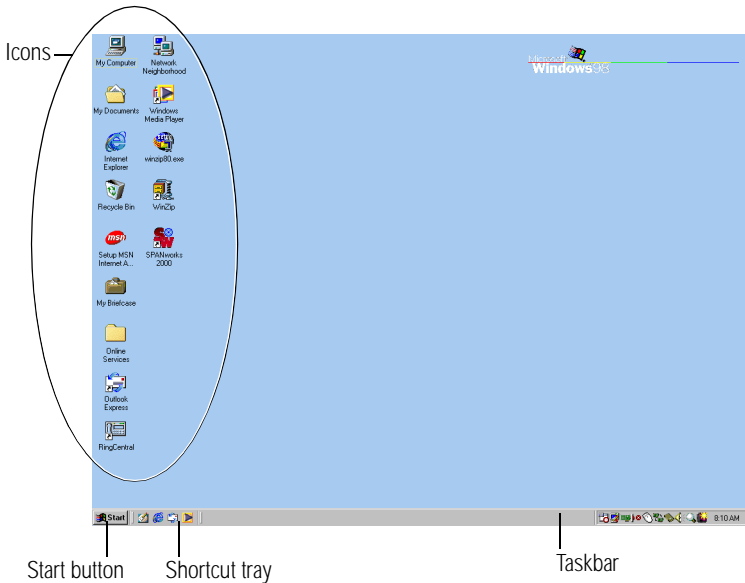

Sample Windows 98 Second Edition desktop

Icons

An icon represents a file or program that can be quickly activated by double-clicking the icon. The icons initially displayed on your Windows 98 Second Edition desktop include:



My Documents — Shows the most recent documents you've created or edited.



My Computer — Shows the file system for your computer and the network (if any).



Network Neighborhood — Shows the current Network sites you are connected to. This icon only appears when you are connected to a LAN.



Recycle Bin — Holds files you've deleted using Windows Explorer. You may retrieve these files until you empty the Recycle Bin.



TECHNICAL NOTE: If you delete a file from a diskette, it does not go into the Recycle Bin. For more information on the Recycle Bin, see Windows Help.



Internet Explorer — The Microsoft browser that provides access to the Internet.



Toshiba VirtualTech™ — A Toshiba utility to help answer technical questions and troubleshoot system problems. For more information about VirtualTech, see [Use VirtualTech on page 212](#).

Your desktop may contain other icons depending on your configuration. See Windows 98 Second Edition online Help for more specific information on each icon and how to use it.

Toshiba Active Menu

The Toshiba Active Menu™ consists of an interactive menu bar and a To Do list.

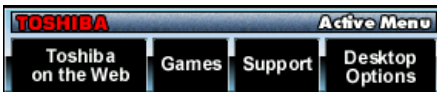

Sample Active Menu

The Active Menu bar provides quick and easy access to Toshiba's Web sites, including product information, services and support, and computer accessory information.

When you click on each Active Menu subject, a drop-down menu appears listing several choices. Click an item in the list to activate that feature.



Sample list of support choices from Active Menu

Many of these items require Internet access. You will be prompted to connect to the Internet (if necessary) when you select an item that references Web content.

The Active Menu also allows you to launch several games and support-related programs, to change the look and feel of the desktop, and to show or hide the Active Desktop components installed on your computer. After several times of use, Active Menu may prompt you of new updated materials in the subject you have clicked on. To update your menu, click on that selection.



Sample To Do List

The To Do list provides a list of things Toshiba recommends you do shortly after purchasing your computer. This includes signing up for free Internet access, registering your computer, learning how to use the Toshiba Active Menu, and familiarizing yourself with the Online User's Guide. The list allows you to check off each item as you complete the associated task.

Desktop wallpaper

The background pattern on the desktop (“wallpaper”) is a graphic image displayed from a file. To change the wallpaper click **Start**, point to **Settings**, click **Control Panel**, and double-click **Display**. Select the Background tab, and choose the background pattern you want displayed on the desktop, Then click **OK**.

Since the Toshiba Active Menu is actually a desktop wallpaper application, changing your wallpaper from the Control Panel will remove it from the desktop. To reinstall the Toshiba Active Menu, click **Start**, point to **Settings**, click **Control Panel**, and double-click **Display**. Select the Background tab, and choose the background pattern called **Toshiba**. Then click **OK**.

To change the wallpaper and retain the Toshiba Active Menu, click on the Active Menu's **Desktop Options**, select **Wallpaper**, and choose the background wallpaper of your choice.

Start button

You use the Start button to:

- ❖ Start programs
- ❖ Access Microsoft Windows 98 Second Edition update information
- ❖ Open documents
- ❖ Adjust system settings
- ❖ Find files
- ❖ Access Windows Help
- ❖ Run programs
- ❖ Suspend system activity and shut down the computer

Shortcut tray

The Shortcut tray displays icons of tasks or programs, similar to desktop icons. You can access these buttons quickly and conveniently at any time as they are not covered by the windows of other executing programs.

To add an icon to the Shortcut tray, drag it to the Shortcut tray.

To activate a specific program, double-click the appropriate Shortcut tray icon.

Taskbar

Each time you open a program, a button associated with that program appears on the Taskbar. With some programs, a button appears on the Taskbar for each document or window you open. You can use these buttons to quickly switch between the programs or windows.

To make a program or window the currently active one, click the associated Taskbar button.

You can personalize the Taskbar to include not only shortcut icons but also your favorite Internet URL addresses.



DEFINITION: URL stands for Universal Resource Locator, which is the address that defines the route to a file on the Web or any other Internet facility. Generically, it is known as the Web site address.

System tray

The System tray displays icons of tasks or programs that run continuously in the background. To learn more about each task, position the cursor over the icon for a few moments and a short description of the task appears.

Typical tasks in the System tray are Current time, Power usage mode, Mouse properties, and speaker volume.

To activate a specific task, double-click the appropriate System tray icon.

Exchanging data with another computer

To transfer a large amount of information between computers, you can use the Windows 98 Second Edition Briefcase, or a specialized synchronization program and the computer's parallel port.

Transferring files

You can transfer files to another computer using your infrared port, or with an adapter cable.

To transfer files through the parallel port, you need an optional LapLink[®]-compatible parallel cable.

- 1 Connect the cable.

- 2 Load the transfer program on both computers.
- 3 Set any specific options.
- 4 Start the transfer.
- 5 When you have finished transferring files, close the programs on both computers.

Getting help transferring files

- 1 Click **Start**, then **Help**.
- 2 Choose the **Index** tab.
- 3 In the dialog box, type direct cable connection.
- 4 Follow the online guide instructions.

An overview of using the Internet

The following sections give a quick introduction to the Internet and some of its exciting features, under these headings:

- ❖ The Internet
- ❖ The World Wide Web
- ❖ Internet Service Providers
- ❖ Connecting to the Internet
- ❖ Surfing the Internet
- ❖ Internet features
- ❖ Uploading and downloading files from the Internet

The Internet

The Internet is an association of thousands of networks and millions of computers around the world connected by communications lines. They all work together to share information.

The World Wide Web

The World Wide Web (or “Web”) is a subset of the Internet — a collection of interlinked documents (located on computers connected to the Internet) that work together using a specific Internet protocol called Hypertext Transfer Protocol (HTTP).

The World Wide Web offers information as text, images, audio, or video to be referenced from anywhere in the world. Special programs called Web browsers are specifically designed to work with HTTP. They make it easier to connect to a particular network address and send and receive information.

Internet Service Providers

To connect a computer directly to the Internet, many people and businesses use an Internet Service Provider (ISP). An ISP is a company that has the equipment and the telecommunication lines necessary to maintain an Internet connection.

You can connect to the Internet by using a telephone and modem or through other higher-speed communication methods such as Digital Subscriber Lines (DSL), cable, and satellite links.

Connecting to the Internet

To connect to the Internet, you need:

- ❖ A modem
- ❖ A Web browser
- ❖ A telephone line
- ❖ An Internet Service Provider (ISP) account

Microsoft’s Web browser Internet Explorer is automatically configured on your system so that when you first start it, it guides you through signing up for a new ISP account with AT&T WorldNet Service, or assists you in setting up your computer to

work with your existing ISP. If you choose to sign up for Internet access with AT&T WorldNet, you will not be charged for the call.

Once you have established an ISP account, you can connect to the Internet.

- 1 Connect your computer's modem to a telephone line. For more information on connecting a modem, see [Connecting the modem on page 44](#).



- 2 Start your Web browser. Have your modem dial the ISP's telephone number, and establish a connection with the ISP's computer.

Toshiba and Yahoo! have joined together to offer you a free account on Yahoo!. In order to sign up for Yahoo!, you must have an Internet access account.

If you are using your computer at the office, then you probably connect to the Internet through your company's network. See your network administrator about connecting to the Internet.

Surfing the Internet

Once connected to the Internet, the Web browser displays a home page, for example, your ISP's home page on the Internet or your company's Web site home page.

To visit a desired Web site, type in the Web address. The Web address, or Uniform Resource Locator (URL), is a unique identifier for that computer system linked to the Internet. Web addresses can also appear within a Web page's text, and are known as links. Clicking a link automatically transfers your Web browser to that site.

You can also use a Search Engine, a Web site specifically designed to help you look for information.

Internet features

The Internet offers many types of communication tools to help you perform many tasks.

- ❖ Internet email

To send and receive email of your own, you need a mailbox on the Web, or an email address.

If you have an account with an ISP, you can probably set up an email address at the same time you sign up for the service.

- ❖ Internet chat rooms

A chat room is a Web site that offers a place where people with similar interests and ideas communicate in real-time, one-on-one or in groups, by typing messages which are instantly viewed by others on their computer screens.

- ❖ Internet news groups

A newsgroup is similar to a chat room, but instead of using a dedicated site to converse about a specialized subject with others in real-time, it uses a Web site as a clearinghouse where all the messages are placed, like a gigantic bulletin board.

- ❖ Online shopping

Many Web sites offer products and services for sale.

Uploading and downloading files from the Internet

Transferring files from one computer to another is termed uploading (transferring data from your computer to a site on the Web), or downloading (transferring data from a site on the Web to your computer).

There are several ways to upload or download data. It can be as simple as attaching a file or document to an email, or you can use the File Transfer Protocol (FTP) features of your Web browser to transfer large amounts of data.

Exploring audio features

You can use your computer to record sounds using an external microphone. You can play .wav sound files or audio CDs using the built-in speakers, headphones or external speakers.

Playing an audio CD

You can use your computer to play audio CDs and to make recordings. For listening to music, you may prefer to use headphones or external speakers instead of the computer's built-in speakers.



WARNING: Before using headphones to listen to an audio CD, turn the volume dial down. Playing the CD with the volume set too high could damage your ears.

To insert a CD in the drive, follow the instructions in [Using compact discs on page 72](#). The computer automatically detects the compact disc in the drive, opens Windows Media Player™ and begins to play the disc.

To access the Windows Media Player, you can open it through the Start menu or activate it from the taskbar.



Stop button
Play/pause button

Sample Windows Media Player screen

The control panel works much like an ordinary compact disc player:

- ❖ To stop the CD, click the **Stop** button.
- ❖ To play the CD or to pause, click the **Play/pause** button.

Recording sounds

You may record sounds as .wav files by connecting an external microphone or other sound source to the microphone jack.



DEFINITION: A .wav (pronounced "wave") file is a format for storing sound in files.

Using a microphone



- 1 Connect an external microphone to the computer.
- 2 Click **Start**, point to **Programs, Accessories, Entertainment**, then click **Sound Recorder**.

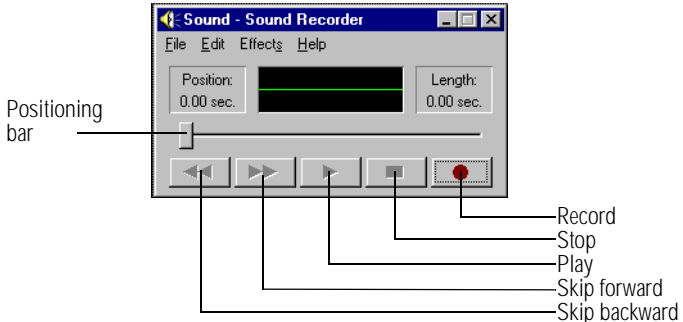

Sound Recorder screen



- 3 Click the **Record** button.

- 4 Speak normally into the microphone.



- 5 When you've finished recording, click the **Stop** button.

The Sound Recorder window displays the new sound file as a waveform.



NOTE: You can only record 60 seconds at a time.



- 6 To hear what you just recorded, click the **Play** button.

- 7 To save the file, select **Save** from the **File** menu.

Adjusting recording quality

The better the quality of the recording, the more disk space the sound file requires. Experiment to find a balance that fits your needs.

- 1 Open Sound Recorder, if necessary. (Click **Start**, point to **Programs, Accessories, Entertainment**, then click **Sound Recorder**.)
- 2 In the Sound Recorder window, click **Edit**, then click **Audio Properties**.
- 3 In the Audio Properties dialog box, adjust the Recording Volume, Preferred device, and Preferred quality.
- 4 Click **OK**.

Your new settings take effect the next time you record.

Using external speakers or headphones

Your computer is equipped with a full stereo sound system with internal speakers. Instead of using the internal speakers, you can connect headphones or a pair of external stereo speakers.



TECHNICAL NOTE: Use amplified speakers that require an external power source. Other types of speakers will be inadequate to produce sound from the computer.



To play back sound files through external speakers or headphones:

- 1 Locate the headphone jack on the computer.
- 2 Using any necessary adapters, plug the cable from the headphones or external speakers into the headphone jack.

The headphone jack requires a 16-ohm stereo mini-jack.

To adjust the volume:

- ❖ For external speakers, use the volume controls on each speaker.
- ❖ For headphones, use the computer's volume control dial.

Exploring audiovisual features

Your computer comes with DVDEExpress™ DVD player software. This provides an easy-to-use, full-featured multimedia control center that helps you get the most out of the exciting world of DVD technology.

Playing a DVD

A DVD automatically starts playing when you insert it and close the drive.



TECHNICAL NOTE: For optimum DVD performance, always play DVDs while your computer is connected to AC power.

When you play a DVD, a Mediamatics DVD Player dialog box may advise you that video and audio playback performance is dependent upon processor speed (MHz) and system configuration.



Video and audio playback performance warning

To access the DVD Player, you can open it through the Start menu before you insert the DVD or, once the DVD is playing, activate it from the taskbar.

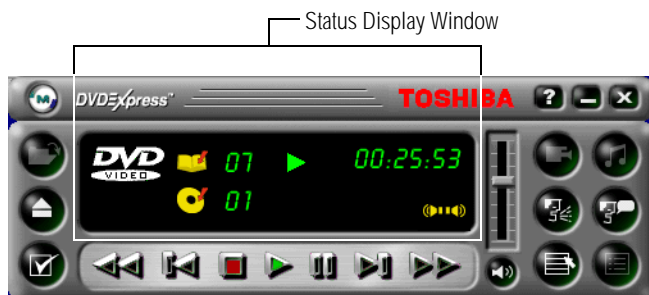

Mediamatics DVDEExpress DVD Player

While your DVD content plays, you have access to all DVDEExpress functions and features. For a detailed description of these features, see [DVD Player controls on page 153](#).



NOTE: DVDEExpress does not support audio compact disc formats. Use CD Player instead.

Playing specific DVD files



- 1 On the DVDEExpress control panel, click the **Open File** button.

The Open file dialog box appears, allowing you to select the desired file by browsing.

- 2 Locate, then double-click the file you want to play.

The selected file begins to play.

To play the same file again, you must reselect the file.

Viewing DVD files on a television

To view a Windows presentation or DVD movie in full-screen mode on a TV, you need a video composite cable, not included with your computer.

- 1 Connect the composite video cable to the television or VCR.
- 2 Select **DVD Options** from DVDEExpress.

See [Starting DVDEExpress on page 152](#).

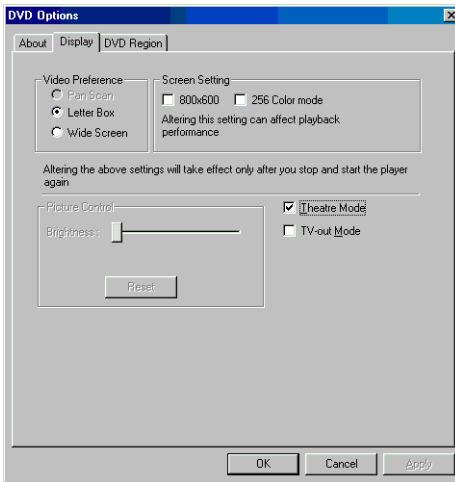

DVD Options window

- 3 Choose the Display tab.
- 4 Check the **TV-out Mode** check box, then click **OK**.
- 5 Click Fn and F5 three times consecutively.

The picture automatically displays on the TV screen.



NOTE: If connecting to a TV through a VCR, select line-in for video throughput. For more information, consult your VCR user's guide.

Viewing the contents of a CD or DVD

CDs and DVDs contain files just like diskettes and the hard disk. CDs are often used to install software or store files that require lots of space, such as photographs and large presentation files. You can use Explorer or My Computer to view the contents of any CD or DVD.

For each installed audio CD title, the hard disk stores a small program that displays the CD's icon. It does not store the CD's content. To view the contents of an audio CD:

- 1 Place the disc in the drive.
- 2 Click **Start**, then point to **Programs**.
- 3 Locate the folder that contains the compact disc icon and title.
- 4 Click the icon.

If you click the icon without having the compact disc in the drive, Windows prompts you to insert the disc.

Emulating a full-size keyboard

Although the computer's keyboard layout is compatible with a standard full-size keyboard, it has fewer keys.

Pressing the Fn key in combination with one of the specially marked function keys allows you to emulate a full-size keyboard. For more information on using Fn key combinations, see [Hot Keys on page 219](#).

Chapter 7

DVDEExpress

Your computer has a DVD-ROM drive, which can read both DVD-ROM and CD-ROM discs.

This chapter documents the features of Mediamatics DVDEExpress, an easy-to-use, full-featured multimedia control center. These utilities help you get the most out of the exciting world of DVD and CD technology.

DVDEExpress

DVDEExpress is the easy way to view and play DVDs. DVDEExpress includes such features as wide-screen movies, multiple language tracks, digital surround sound, multiple camera angles, and interactive menus. The computer can play high-resolution video at up to 30 frames per second.



TECHNICAL NOTE: For optimum DVD performance, always play DVDs while your computer is connected to AC power.

Starting DVDE_{Express}

- 1 Open the **Start** menu.
- 2 Point to **Programs** then **Mediamatics DVDE_{Express}**.
- 3 Click **Mediamatics DVD Player**.

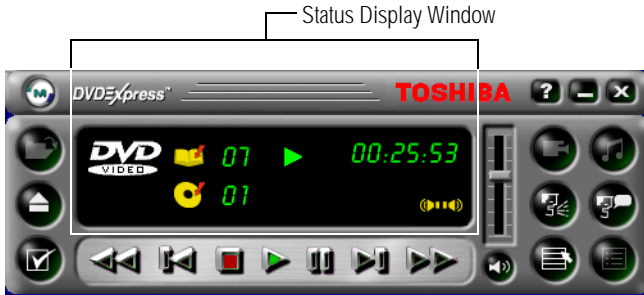

Mediamatics DVDE_{Express} DVD Player

Status display window

This window displays information about the content currently being played. In addition to the current play state (playing, paused, etc.) and the elapsed time, the window includes the following indicators:

Disc type indicates one of the following:



- ❖ DVD Video



- ❖ Audio CD



Chapter — Indicates the chapter number being played.



Title/Track — Indicates the title or track number being played.



This indicator is displayed on Dolby-certified systems.

Audio mode indicates the current audio mode:



❖ Stereo

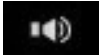

❖ Right



❖ Left



❖ 3-D Stereo



❖ Mute

DVD Player controls

The Mediamatics DVDEExpress DVD Player resembles a standard home VCR, but it also has features that are unique to the DVD medium.

Following is a summary of the functions of the DVD Player controls and indicators:



Open — Opens video and/or audio files for selection and playback.

Keyboard shortcut: L



Eject — Opens the DVD-ROM drive for loading and/or removal of discs. Some systems also use this button as a toggle between Eject and Insert.

Keyboard shortcut: E



Options — Displays the DVDEExpress Options dialog box, which provides information about the application and allows you to modify a number of settings.

Keyboard shortcut: None



Rewind — Moves the content back to a selected location. Click **Play** to resume playback.

Keyboard shortcut: B



NOTE: Some dialog pages will not appear while content is playing.



Previous — Moves the content back to the previous chapter or track and resumes playback.

Keyboard shortcut: <



Stop — Ceases playing content and displays the DVDE^xpress splash screen. To resume playback, click **Play** and the content will play from the start of the content file.

Keyboard shortcut: S



Play — Begins playback of selected content.

Keyboard shortcut: Enter



Pause — Temporarily stops content playback. Click **Pause** or **Play** to resume playback.

Keyboard shortcut: P



Next — Advances the content to the next chapter or track and resumes playback.

Keyboard shortcut: >



Fast Forward — Moves forwards through the content at double speed to a selected location. Click **Play** to resume playback.

Keyboard shortcut: F



Volume — Increases the volume level when you drag the bar up and decreases the volume level when you drag the bar down.

Keyboard shortcut: + to increase volume
- to decrease volume



Mute — Suppresses the audio track. Click the **Mute** or Volume Control buttons to resume audio.

Keyboard shortcut: M



Help — Displays the Help file.

Keyboard shortcut: F1



Minimize — Minimizes the DVDEExpress display window.

Keyboard shortcut: N



Close — Closes the DVDEExpress application.

Keyboard shortcut: X



Camera Angle — Changes the camera angle (or view) of the content currently being played. This feature is enabled by the DVD content and is only available when the content was created using multiple cameras and camera angles.

Keyboard shortcut: V



NOTE: Due to differences in the content mastering process, some multi-angle views may not function properly.



3D Audio — Turns the 3D audio or virtual surround sound feature on and off. This button becomes active only when the appropriate 3D audio component is present in the system.

Keyboard shortcut: A



Audio — Changes the audio track currently being played to another audio track located on the DVD disc. This feature is most commonly used with multi-language content to change the spoken/heard language. This feature is enabled only when the content allows dynamic changes of the audio track.

Keyboard shortcut: 0



NOTE: Some audio changes must be made through the Title or Root menu.



Subtitle — Displays or changes subtitles to be viewed on-screen. This feature is enabled only for DVD content that includes subtitles and offers the ability to make dynamic changes of subtitle information. Some subtitle changes must be made through the Main Menu.

Keyboard shortcut: U



Root Menu/Resume — Displays the DVD root menu for selection of DVD content for playback. The functionality of the Resume feature depends on the content being played. Some content resumes playback when you click the Root Menu/Resume button again. This action starts the playback of the content from the location where you left the content for the Root Menu. Other content requires an action within the menu (for example, click **Play Movie**) to resume playback.

Keyboard shortcut: R



Title Menu/Resume — Displays the Title Menu for selection of content for playback. The functionality of the Resume feature depends on the content being played. Some content resumes playback when you click the Title Menu/Resume button again. This action starts the playback of the content from the location where you left the content for the Title Menu. Other content requires an action within the menu (for example, click **Play Movie**) to resume playback.

Keyboard shortcut: T

Using the DVDE^xpress shortcuts

The shortcut keys available in DVDE^xpress are listed in the controls and indicators table starting on [page 153](#).



HINT: To display the DVDE^xpress control panel when the video is in full screen mode, move your mouse pointer out of the screen area (for example, to the bottom of the screen).

Accessing the shortcut menu



Shortcut menu

The shortcut menu appears when you click the secondary AccuPoint II button on the DVDEExpress control panel. It offers alternative access to a number of features.

Using DVDEExpress options

The Options window provides information about the application and allows you to modify a number of settings. To access DVDEExpress DVD options:

- 1 Launch DVDEExpress, if it is not already running.
- 2 On the DVDEExpress control panel, click the **Options** button.



DVDEExpress options

The DVD Options dialog box contains the following tabs:

- ❖ **About** — This tab displays copyright, trademark, version number, Region Code and other relevant information about your DVDEExpress application.
- ❖ **Audio** — Use this tab to enable or disable Digital Audio Output (SPDIF output). The Audio tab appears only if certain

audio hardware is present in your system. It also appears only when playback is stopped.

- ❖ **Display** — Use this tab to select or modify various video and display settings. This tab is available only when playback is stopped.
- ❖ **DVD Region** — Use this tab to change the current region code for DVDE^xpress. This tab is only available when playback is stopped.

Region codes

Region coding is part of the protection system for DVD content. It divides the world into six regions. The intent is to enable specific content to be viewed in a specific region.

The current region code of the DVDE^xpress player installed in your computer is Region 1, comprising the United States and Canada. The region code is provided on the About tab in the DVD Options dialog box. It is noted in parenthesis following the application version number.

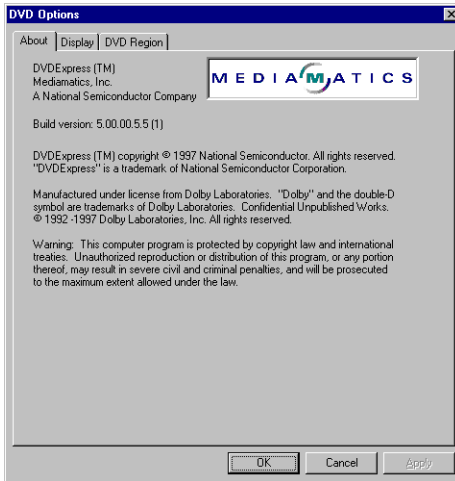

DVD region dialog box

Chapter 8

Toshiba Utilities

Your computer includes several utilities designed to help you to reconfigure your system to best meet your individual needs. Together, these allow you to determine certain system details, set additional options or change default options. This chapter describes the utilities supplied by Toshiba:

- ❖ Fn-esse
- ❖ Toshiba Services
- ❖ Toshiba Hardware Setup
- ❖ Toshiba Power Saver utility
- ❖ Hibernate tab in Power Management
- ❖ Setting user passwords
- ❖ Using a supervisor password

Fn-esse

Windows 98 Second Edition shortcuts and Toshiba's Fn-esse program provide quick ways to open programs, documents, and folders from within any Windows program without using the Start menu. For more information on creating Windows 98 Second Edition shortcuts, refer to the operating system documentation that came with your computer.

This section describes how to use the Fn-esse program to quickly access your programs and files.

With Fn-esse, you can assign an Fn key combination to:

- ❖ Open a Windows 98 Second Edition program.
- ❖ Open a file in its associated Windows 98 Second Edition program.
- ❖ Display a customized folder of Windows 98 Second Edition programs and/or files from which to choose.

Fn-esse also has several keys, known as hot keys, that perform preassigned operations. For more information, see [Hot Keys on page 219](#).

You can assign any key that is not associated with a hot key or a keyboard overlay.

Starting Fn-esse

- 1 Click **Start**, point to **Programs**, **Toshiba Utilities**, then click **Fn-esse**.

The Fn-esse keyboard appears.



Fn-esse window

The keys are color-coded as follows:

- ❖ Available keys are black
- ❖ Assigned keys and keys associated with a popup list are shown on the Fn-esse keyboard in the selected color
- ❖ Unavailable keys are dark gray

Assigning a key to a program or document

There are two ways to assign a key to open a program or document:

- ❖ Using drag-and-drop
- ❖ Using the keyboard or pointing device

The method most often used is drag-and-drop.

Using drag-and-drop

To assign a key to a program or document:

- 1 Start both Fn-esse and Windows Explorer (or the program supporting drag-and-drop).

- 2 Resize the Explorer window so that you can see both the Fn-esse keyboard and Explorer at the same time.
- 3 In the Explorer window, highlight the program or document file you wish to assign to a key.
- 4 Click and hold the primary button as you drag the highlighted item from Explorer to the key on the Fn-esse keyboard to which you want to assign it.
- 5 Release the primary button.

Fn-esse displays the Add/Edit Command dialog box with the Description, Command Line and Working Directory fields automatically completed.

- 6 Click **OK** to close the Add/Edit Command dialog box with your key assignment in place.

The program or document is now associated with the key you just selected. To open the program or document, press Fn plus the appropriate key from within any Windows program.

Using the keyboard or pointing device

To assign a key to open a program or document:

- 1 Start Fn-esse.
- 2 Do one of the following:
 - ❖ Using the keyboard, press and hold the Fn key, then press the desired assignment key.
 - ❖ Using the pointing device, move the cursor over the desired key and press the secondary button.

The Assignment Type dialog box appears.



HINT: If you are making a direct key assignment, complete step 3. If you are making a popup assignment, complete step 4.

- 3 To make a direct key assignment, select **Direct** to display the Add/Edit Command dialog box.
 - ❖ Enter the Description, Command Line and Working Directory for the new Fn-esse key assignment, or click the **Browse** button to specify this information.
 - ❖ Click **OK**.
- 4 To make a popup assignment, select **Popup** to display the Application Explorer dialog box.
 - ❖ Select the desired folder. The left side of the Application Explorer window displays the folders in the Programs menu. The right side lists the programs and documents in the folder. These are the items that will appear in the popup list.
 - ❖ To create a popup list with items from various folders, or to pick only a few items from a folder, create a new folder containing only the desired programs and documents. If you are unsure how to do this, refer to your Windows 98 Second Edition documentation.
 - ❖ Click **OK** to associate the folder with the key you just selected.
 - ❖ To open a popup list showing the items in that folder, press Fn plus the appropriate key from within any Windows program.

Viewing existing key assignments

To view the existing key assignments, choose **Assignments** from the Fn-esse keyboard. Fn-esse displays the Function Key Assignments dialog box. This box lists all the key assignments and the program or document to which each key is assigned.

To view items in a popup list, click the **Expand popup lists** check box.

Changing or removing existing key assignments

- 1 In the Fn-esse keyboard, click the key you wish to change with the secondary button.
Fn-esse displays the Assignment Type dialog box.
- 2 To change the key assignment, click **Direct** or **Popup** and continue as if you were creating a new assignment.
- 3 To remove the key assignment, click **Clear**.

Toshiba Services

The Toshiba Services utility allows you to enable or disable hot keys.

Enabling hot key services

Toshiba has defined a number of hot keys that make it easy to change your display brightness or power settings.

To enable or disable hot key services:

- 1 Open the **Start** menu, point to **Settings**, then click **Control Panel**.
- 2 In the Control Panel window, double-click the **Toshiba Services** icon, then click the **Hotkey** tab.

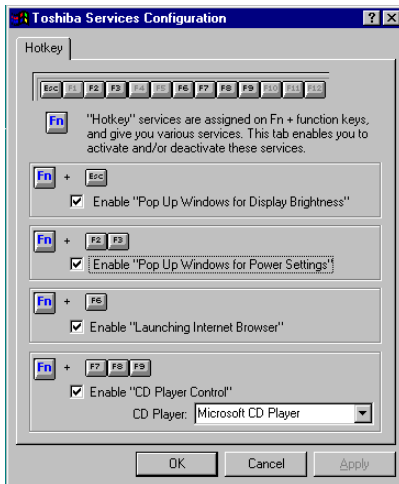

Toshiba Services Hotkey dialog box

- 3 Select or clear the check box for each hot key you want to enable or disable, then click **OK**.

Toshiba Hardware Setup



Toshiba Hardware Setup is the Toshiba configuration management tool available through Windows. To access it, open the **Start** menu, point to **Settings, Control Panel**, then click **Toshiba Hardware Setup**.

There are several tabs representing various dialog boxes. They are:

- ❖ **Boot Priority** — Allows you to change the sequence in which your computer searches the drives for the operating system.
- ❖ **Keyboard** — Allows you to assign as well as disable various key combinations.
- ❖ **USB** — Allows you to enable or disable USB legacy emulation.
- ❖ **Pointing Devices** — Allows you to select types of devices.
- ❖ **Hardware Alarm** — Allows you to control alarm volume and whether an alarm sounds when the battery power is low or when you close the display panel while the computer is on.
- ❖ **General** — Allows you to view current BIOS, hard disk drive and memory settings.
- ❖ **Device Config** — Allows you to select device configurations.
- ❖ **Parallel/Printer** — Allows you to select the printer port type.
- ❖ **Password** — Allows you to set user passwords. If you do this, you can use SecureSleep™ to protect your work by requiring the password to be entered before accessing Windows.
- ❖ **Display** — Allows you to change various settings for the built-in display.
- ❖ **PC Card** — Allows you to change the controller mode settings.
- ❖ **CPU** — Allows you to enable or disable the processor serial number, and to set the “CPU Frequency Mode” to either

“Dynamically Switchable,” “Always High,” or “Always Low.”

Dynamically Switchable — This mode is the default setting for your computer.

- ❖ AC Power — If your computer is connected to the AC adapter, the CPU mode is set to high for faster processing.
- ❖ Battery Power — If your computer is running on battery power, the CPU mode is set to low, for slower processing. Switching the CPU to low allows you to conserve power and extend the operating time of your battery.

Always High — This mode sets the CPU to high when using either the battery or the AC adapter.

Always Low — This mode sets the CPU to low when using either the battery or the AC adapter.

By changing any of the options that appear in the dialog boxes and clicking **Apply**, you can reconfigure that function. Any options that you change will not take effect until after you restart your system.

Toshiba Power Saver utility

Toshiba's Power Saver utility enhances your computer's power management capabilities. It controls the computer's Power Save Mode, which is a series of settings for power management. In the Power Save Properties dialog, you can choose which mode to use, change settings for each mode, or create your own mode.

To access Power Saver Properties:

- 1 Open the **Start** menu, point to **Settings**, then click **Control Panel**.
- 2 In the Control Panel window, double-click the **Power Saver** icon.

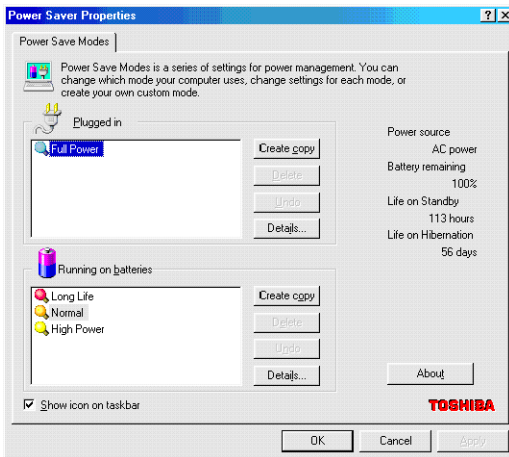

Power Saver dialog box

By changing the options that appear in the Power Saver Properties dialog box and clicking **OK**, you can reconfigure that function.

You may choose a power-saving management strategy to best suit your computing needs. If you are running on batteries and the programs that you are using do not require a lot of system resources, you may experience longer work sessions by enabling the Normal or Long Life settings.

Any options that you change become effective when you click either **OK** or **Apply**.

Hibernate tab in Power Management

Microsoft Windows 98 Second Edition includes a Power Management utility that allows you to change many of your default power settings.



NOTE: Toshiba recommends that you use the Microsoft Power Manager to set the Hibernation option only.

For other power-saving options, use the Toshiba Power Saver utility.

To access the Power Management program:

- 1 Open the **Start** menu, point to **Settings**, then click **Control Panel**.
- 2 In the Control Panel window, double-click the **Power Management** icon.

A dialog box appears advising you to use Power Saver to adjust the computer's power management settings.

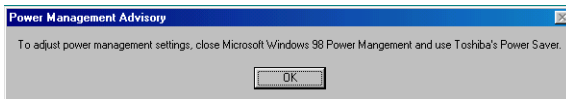

Power Management Advisory dialog box

- 3 Click **OK** to close the dialog box.

The Power Management Properties dialog box appears.

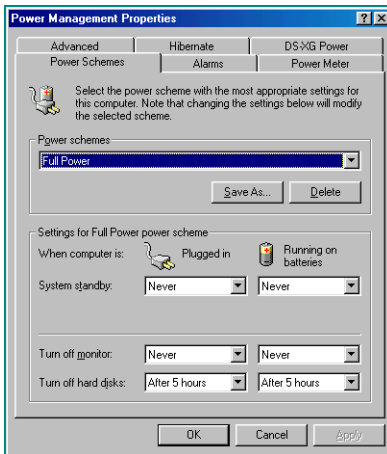

Power Management Properties dialog box

The Power Management Properties dialog box contains the following tabs:

- ❖ **Power Schemes** — Allows you to choose from among a group of preset power options.
- ❖ **Advanced** — Allows you to choose additional power management options.
- ❖ **Alarms** — Allows you to change the settings for the battery alarms.
- ❖ **Hibernate** — Allows you to change the default setting of Hibernation mode.
- ❖ **Power Meter** — Gives you details about your power sources.

- ❖ DS-XG Power — Allows you to set the power mode for the DS-XG audio device.



TECHNICAL NOTE: Toshiba recommends that you always have the Hibernation option enabled. Hibernation is the function that causes your system to save anything you have in short-term memory to the hard disk drive should your battery fail. If Hibernation is not enabled and your battery dies, you will lose data.

Setting user passwords

Setting a password lets you leave your computer, secure in the knowledge that nobody can access your files. You must enter the password before you can work on your computer again.

Toshiba supports the following types of passwords on your computer:

- ❖ An instant password secures your open programs and files when you need to leave the computer temporarily
- ❖ A power-on password prevents unauthorized users from starting or restarting the computer
- ❖ A hard disk drive password prevents access to the hard disk even if it is removed and installed in another computer
- ❖ A supervisor password prohibits unauthorized users from accessing certain functions such as Toshiba Hardware Setup. This is useful if more than one person uses the computer

A single user password supports the instant and power-on password functions.

Using an instant password

An instant password secures your system with a single keystroke. Use this feature when you need to leave your desk for a few minutes and don't want to turn off the computer.

To use an instant password, press Fn, then press F1. This freezes the keyboard and AccuPoint II and blanks the screen. An instant password has no effect on an optional serial mouse or trackball.

- 1 To unlock your system, do one of the following:
 - ❖ If you have not registered a user password, press Enter.
 - ❖ If you have registered a user password, press Enter. Type your password then press Enter.

If you enter the password correctly, the computer returns to where it was when you enabled the instant password.

Setting a user password

To register a password for the instant and power-on password functions:

- 1 Open the **Start** menu, point to **Settings, Control Panel**, then click **Toshiba Hardware Setup**.
- 2 Select the **Password** tab.
- 3 Click **Registered**.
- 4 Type your password in the Enter Password box and click **OK**.
- 5 Type the password again in the Verify Password box and click **OK**.
- 6 Click **Exit**.

Disabling a user password

To cancel the password that supports the instant and power-on password functions:

- 1 Open the **Start** menu, point to **Settings, Control Panel**, then click **Toshiba Hardware Setup**.
- 2 Select the **Password** tab.
- 3 Click **Not Registered**.
- 4 Type your password in the Enter Password box and click **OK**.



TECHNICAL NOTE: You have three tries to enter the correct password. After an incorrect try, an "Incorrect Password" dialog box will appear. Click OK to reenter the password.

After three incorrect tries, the following message appears: "Sorry, access denied! Reboot is required to regain access." You will need to turn off the computer, then reboot.

- 5 Click **Exit**.

Using a supervisor password

A supervisor password prevents other users from changing hardware configuration options.

Setting a supervisor password

- 1 Click **Start**, then click **Shut Down**.
The Shut Down Windows dialog box appears.
- 2 Select **Shut down** and click **Yes**.
Windows 98 Second Edition shuts down and turns off the computer automatically.
- 3 Insert the Toshiba Companion Diskette into the diskette drive and turn on the computer.
After a few minutes, a Welcome screen appears.
- 4 Press Enter.

The Toshiba Companion Utility main menu appears.

- 5** Use the arrow keys to select **Exit to DOS**.

- 6** At the A:\ prompt, type
c:\program files\toshiba\windows utilities\svpwtool\svpw32.exe
and press Enter.

The following message appears:

SUPERVISOR PASSWORD = Not Registered

Do you want to register the supervisor password <Y/N>?

- 7** Type Y to set a supervisor password.

The following prompt appears:

Enter Password -->

- 8** Type in a password of up to ten characters and press Enter.

The following prompt appears:

Verify Password -->

- 9** Reenter the password and press Enter.

The following message appears:

SUPERVISOR PASSWORD = Registered

- 10** If the password is incorrect, the following message appears:

Password verify error!

Do you want to retry <Y/N>?

Type Y and reenter the password.



TECHNICAL NOTE: After three attempts to enter the correct password, the utility exits to the system prompt without setting a supervisor password.

- 11** Press Ctrl, Alt, and Del simultaneously to return to Windows 98 Second Edition.

Deleting a supervisor password

- 1 Click **Start**, then click **Shut Down**.

The Shut Down Windows dialog box appears.

- 2 Select **Shut down**.

Windows 98 Second Edition shuts down and turns off the computer automatically.

- 3 Insert the Toshiba Companion Diskette into the diskette drive and turn on the computer.

After a few minutes, a Welcome screen appears.

- 4 Press Enter.

The Toshiba Companion Utility main menu appears.

- 5 Use the arrow keys to select **Exit to DOS**.

- 6 At the A:\ prompt, type `c:\dos\svpw` and press Enter.

The following message appears:
SUPERVISOR PASSWORD = Registered
Do you want to delete the supervisor password <Y/N>?

- 7 Type Y.

The following prompt appears:
Enter Password -->

- 8 Enter the password and press Enter.

- 9 At the system prompt, type `c:\dos\svpw` and press Enter.

If the password is correct, the following message appears:
SUPERVISOR PASSWORD = Not Registered

- 10 If the password is incorrect, the following message appears:

Password verify error
Do you want to retry <Y/N>?

Type Y and reenter the password.

- 11** Enter the password and press Enter.
-



TECHNICAL NOTE: After three attempts to enter the correct password, the utility exits to the system prompt without deleting the supervisor password.

- 12** Press Ctrl, Alt, and Del simultaneously to return to Windows 98 Second Edition.

Chapter 9

If Something Goes Wrong

Some problems you may encounter when using your notebook computer are relatively easy to identify and solve. Others may require help from your dealer or the manufacturer of a software program.

This chapter aims to help you solve many problems yourself without needing additional help. It covers the problems you are most likely to encounter. For further assistance and solutions, use Toshiba's support tool, VirtualTech, to help diagnose and solve possible problems.

If all else fails, contact Toshiba. You will find information on Toshiba's support services at the end of this chapter.

Problems that are easy to fix

Your program stops responding.

If you are working with a program that suddenly freezes all operations, chances are the program has stopped responding. You can exit the failed program without shutting down Windows 98 Second Edition or closing other programs.

To close a program that has stopped responding:

- 1 Press **Ctrl, Alt, and Del** simultaneously (once).

Windows 98 Second Edition displays the **Close Program** dialog box. This box lists all the programs and processes currently in operation. If a program has stopped responding, the words “not responding” appear beside its name in the list.

- 2 Select the program you want to close, then click **End Task**.

Closing the failed program should allow you to continue working. If it does not, continue with step 3.

- 3 Close the remaining programs one by one by selecting the program name, then **End Task**.

- 4 Click **Shut Down**.

Windows 98 Second Edition displays the **Shut Down Windows** dialog box.

- 5 Select **Restart**, then click **Yes**.

Your computer shuts down and restarts Windows 98 Second Edition, thus restoring operations.



*CAUTION: Typing **Ctrl, Alt, and Del** simultaneously twice to restart your computer is not recommended. By closing all open programs prior to shutting down Windows 98 Second Edition you ensure that all data is saved.*

Your program performs an illegal operation.

If you receive the message, “Your program has performed an illegal operation,” you should record the details of the message and consult the software manufacturer.

To record the details:

- 1 Click the **Details** button and select the text Windows 98 Second Edition displays.

The Details button displays information that the software manufacturer needs to help you solve your problem.

- 2 Press Ctrl and c simultaneously to copy the text to the clipboard.
- 3 Open Notepad (click **Start**, point to **Programs**, then point to **Accessories** and click **Notepad**).
- 4 Press Ctrl and v simultaneously to paste the details into Notepad.
- 5 Add a paragraph break and type some notes describing what you were doing when you received the message.
- 6 Save the file and refer to it when you contact the software manufacturer.

You open a program that immediately stops responding.

If CPU Sleep mode is on (enabled), it may stop a program from responding. Close the program you are trying to open and turn off (disable) Sleep mode. Then, try to run the program again.

To close the program:

- 1 Press Ctrl, Alt, and Del simultaneously.

The Close Program dialog box displays all the programs and processes currently in operation. If the program has stopped responding, the words “not responding” appear beside it.

- 2 Click **End Task**, then click **Cancel**.

To disable Sleep mode:

- 1 Turn off the computer.
- 2 Hold down the Esc key and turn on the computer.

The following message displays:

Check system. Then press [F1] key

- 3 Press F1.

The computer displays a setup screen.

- 4 Using the arrow keys, highlight **Battery Save Mode**, then choose **User Settings** from the drop-down list.
-



HINT: This is the only way you can access the CPU Sleep mode function.

- 5 Set CPU Sleep mode to **Disabled**.
- 6 Press End, then enter Y to save your changes and exit.
- 7 Restart your computer.

If the problem continues, contact the manufacturer of the program.

Problems when you turn on the computer

These problems may occur when you turn on the power.

The computer will not start.

Make sure you attached the AC adapter and power cable properly or installed a charged main battery.

Press and hold down the power button for a few seconds.

The computer starts but, when you press a key on the keyboard or touch the AccuPoint II, nothing happens.

To clear the condition, press Ctrl, Alt, and Del simultaneously, or press the reset button.

Clearing the condition may get you running, but it won't solve a resource conflict. Read the documentation that came with the conflicting device and [Resolving a hardware conflict on page 187](#).

The computer is not accessing the hard disk drive.

Your computer normally loads Windows from the hard disk. If you have a hard disk problem, you will not be able to start the

computer. Insert a system diskette into the diskette drive and press F10 while you turn on the power.

The computer displays the WARNING RESUME FAILURE message.

The computer was placed in Standby and the main battery has discharged. Data stored in the computer's memory has been lost.

To charge the main battery, leave the computer plugged into a live wall outlet for about three hours. For more information, see [Power and the batteries on page 191](#).

The computer displays the Non-System disk or disk error message.

Make sure there is no diskette in the diskette drive. If there is one, remove it and press any key to continue. If pressing any key does not work, press Ctrl, Alt, and Del, or press the reset button to restart the computer.

If the problem persists, try restarting the computer with the Toshiba Companion Diskette or another reliable system diskette in the diskette drive.

Windows 98 Second Edition is not working

Once you are familiar with the desktop and used to the way Windows 98 Second Edition responds to your work routine, you can easily detect if the operating system is not working correctly. For example:

- ❖ Windows 98 Second Edition fails to start after the Starting Windows 98 message appears.
- ❖ Windows 98 Second Edition takes a long time to start.
- ❖ Windows 98 Second Edition responds differently from the normal routine.
- ❖ The screen does not look right.

Unless a hardware device has failed, problems usually occur when you change the system in some way such as installing a new program or adding a device.

If you experience any of these problems, use the options in the Windows 98 Second Edition Startup menu to fix the problem.

Using Startup options to fix problems

If Windows 98 Second Edition fails to start properly, you may have to change your system's configuration or verify the startup procedure to fix the problem. To do this, use the options in the Windows 98 Second Edition Startup menu. This section describes each option and when to use the procedure.

To open the Startup menu:

- 1 Restart your computer.
- 2 Press F8 when your computer starts.

The Startup menu displays these options:

- ❖ Normal
- ❖ Logged (\BOOTLOG.TXT)
- ❖ Safe mode
- ❖ Step-by-step confirmation
- ❖ Command prompt only
- ❖ Safe mode command prompt only



TECHNICAL NOTE: If your computer is connected to a network, the Start up menu may display different versions of Safe mode.

Normal

Selecting Normal starts Windows 98 Second Edition under normal conditions. Start the computer in Normal mode when there are no apparent problems with the system.

Logged (Bootlog.txt)

Selecting Logged starts Windows 98 Second Edition under normal conditions and creates a hidden startup log file named `c:\Bootlog.txt`. This file records every step of the system's startup process.

You or a qualified Windows 98 Second Edition expert can use this log file to check the loading and initializing of device drivers.



DEFINITION: A device driver is a file that contains information to help the computer's BIOS (Basic Input/Output System) control the operation of devices connected to the system.

Safe mode

Selecting Safe mode bypasses basic startup files and starts Windows 98 Second Edition, enabling only the mouse, keyboard, and standard VGA display drivers.

Running Safe mode allows you to undo any changes you made to the system configuration that may have caused Windows 98 Second Edition or a device to fail. For example, if you choose a resolution that is not supported by the display, the operating system will have a problem starting correctly. Safe mode bypasses the setting and allows you to change the resolution to one supported by the display. Once you have done this, Windows 98 Second Edition will start correctly.

Other problems may involve a device driver. See [Windows 98 Second Edition can help you on page 186](#) to fix the problem.



TECHNICAL NOTE: Windows 98 Second Edition automatically starts in Safe mode if it detects that system startup failed or the Registry (the file that defines how Windows 98 Second Edition is set up) is corrupted.

Step-by-step confirmation

When you turn on your computer, Windows 98 Second Edition processes the startup files. With Step-by-step confirmation, the system asks you to confirm each line of the startup process once it appears.

Use this option when:

- ❖ The startup process fails while loading the startup files
- ❖ You need to verify all drivers are being loaded
- ❖ You need to temporarily disable one or more specific driver(s)
- ❖ You need to check for errors in the startup files

Windows 98 Second Edition uses a file called IO.SYS, which contains all the information needed to start the computer. Although your computer does not need the Config.Sys and Autoexec.Bat files to start, it does process these files to support backward compatibility with some programs and device drivers. The same holds true for the System.Ini and Win.Ini files.



TECHNICAL NOTE: Programs and devices that are backward compatible are designed to work with older operating systems and other programs. For example, many features of Windows 98 Second Edition are backward compatible with earlier versions of Windows. This lets you use older programs with Windows 98 Second Edition.

Most of the information contained in these files is now stored in the Registry. However, they are still processed during system startup. Bootlog.Txt file contains a record of all the components and drivers loaded during startup and the status of each. When you select Step-by-step confirmation, you can view all these files one line at a time to help diagnose the cause of a problem.

Command prompt only

Selecting Command prompt only starts the basic operating system with all the startup files and device drivers.

Use this option when you want to run MS-DOS or Windows 98 Second Edition commands. This option is for advanced users who are familiar with MS-DOS and know what these commands do.

Safe mode command prompt only

Selecting Safe mode command prompt only bypasses the system start-up files and displays the command prompt.

Use this option under these conditions:

- ❖ Windows 98 Second Edition fails to start even in Safe mode
- ❖ You want to run MS-DOS commands such as Edit to make changes to your startup files
- ❖ You want to avoid loading Himem.Sys (extended memory manager), or Ifshlp.Sys (file system manager)

Internet problems

My Internet connection is very slow.

Many factors contribute to the speed with which you can surf the Internet. They include: modem speed, time of day (when everyone else is surfing, your access can be slow) and popularity of the site. If accessing a particular site is very slow, try later.

My browser can't find the URL address I typed in.

Make sure you separated the domain names of the address with the forward slash (/). Check the spelling of each name and the syntax of the address carefully. A single incorrect letter, missed period (“dot”) or other mistake makes it impossible for your browser to locate the site.

My browser can't find a site I bookmarked.

The World Wide Web is constantly changing. A site you bookmarked yesterday may not be available today or its server may be down for temporary repair. Try again later.

Windows 98 Second Edition can help you

If Windows 98 Second Edition has started properly, but you still have a problem using your computer, the online Help can assist you in troubleshooting the problem.

To access Windows 98 Second Edition Help:

- 1** Click the **Start** button and click **Help**.
- 2** Click the **Contents** tab, then double-click **Troubleshooting**.
- 3** Double-click a problem you would like help with, and follow the steps on the screen.

Working with troubleshooters

Windows 98 Second Edition includes a wide range of helpful troubleshooters that can assist you with many common computer problems. For instance, if you are having difficulty setting up a new printer, the Print troubleshooter can walk you through the setup process step by step. Troubleshooters are available through Windows Help, and they are constantly updated and supplemented on the Microsoft Support Online Web site.

You can connect to Support Online by clicking the **Web Help** button in Windows Help or by connecting to:

www.support.microsoft.com/support/

Resolving a hardware conflict

If you receive an error message telling you there is a device driver conflict or a general hardware problem, try using Windows 98 Second Edition Help to troubleshoot the problem first.

For help on hardware conflicts:

- 1 From the Windows **Help** menu, click the **Contents** tab, then double-click **Troubleshooting**.
- 2 Click **hardware conflict** and follow the steps.

If there is still a problem, Windows 98 Second Edition should display a message that explains what the conflict is. If this happens, you may need to solve the problem on your own.

A plan of action

The smooth operation of the system depends on the interaction of all devices, programs, and features. If the system or one of its attached devices isn't working, resolving the problem can be time-consuming and frustrating.

The recommended procedure for getting multiple devices to work together is to add and set up one device at a time. After you add each device, test it to make sure it and all previously connected devices work.

The device most recently connected to the system is the one most likely to be causing a hardware conflict.

Resolving hardware conflicts on your own

Computer components need resources to accomplish a task. A device, such as a CD-ROM drive or a modem, needs a channel to

the computer's Central Processing Unit (CPU). It also needs a direct channel to the computer's memory to store information as it works. These channels of communication are commonly referred to as system resources.

Interrupt Request Channel

The channel to the CPU is called an Interrupt Request (IRQ) because it interrupts what the processor is doing and requests some of the processor's time. If two or more devices use the same IRQ channel, the processor does not know which device is asking for attention. This causes a hardware conflict.

Direct Memory Access

Similarly, the data required by the device is stored in a specific place or address in memory called the Direct Memory Access (DMA). The DMA provides a dedicated channel for adapter cards to bypass the microprocessor and access memory directly. If two or more devices use the same DMA, the data required by one device overwrites the data required by the other, causing a hardware conflict.

Plug and Play

With Plug and Play and Windows 98 Second Edition, avoiding hardware conflicts is easy. Plug and Play is a computer standard that helps the BIOS (basic input/output system) and the operating system to automatically assign system resources to Plug and Play-compliant devices. In theory, if every device connected to the computer is Plug and Play-compliant, no two devices will compete for the same system resources. You simply plug in the device and turn on your computer. Windows 98 Second Edition automatically sets up your system to accommodate the new device.

However, if you install an older (legacy) device that Windows 98 Second Edition cannot recognize, the operating system may have

difficulty assigning resources to it. As a result, a hardware conflict can occur. To see what resources Windows 98 Second Edition has assigned to the device, see [Checking device properties on page 190](#).

Resolving conflicts

There are three things you can do to resolve hardware conflicts.

- ❖ Disable the device.

For an older device, remove it from the computer. For a Plug and Play device, see [Fixing a problem with Device Manager on page 189](#).

- ❖ Disable another system component and use its resources for the new device. See [Fixing a problem with Device Manager on page 189](#).

- ❖ Reconfigure the device so its requirements do not conflict. Refer to the device's documentation for instructions about changing settings on the device.

Fixing a problem with Device Manager

Device Manager provides a way to check and change the configuration of a device.



CAUTION: Changing the default settings using Device Manager can cause other conflicts that make one or more devices unusable. Device Manager is a configuration tool for advanced users who understand configuration parameters and the ramifications of changing them.

Disabling a device in Windows 98 Second Edition

- 1 Click the **My Computer** icon with the secondary button, then click **Properties**.

Windows 98 Second Edition displays the System Properties dialog box.

- 2 Click the **Device Manager** tab.
- 3 Select the device and click **Properties**.
A dialog box displays the device's properties.
- 4 In the General section of the dialog box, check the box next to **Disable in this hardware profile**.
- 5 Click **OK**.

Checking device properties

Device Manager provides a way to view the properties of a device. Properties include the name of the manufacturer, the type of device, the drivers installed, and the system resources assigned to the device.

To check a device's properties:

- 1 Click the **My Computer** icon with the secondary button, then click **Properties**.

Windows 98 Second Edition displays the System Properties dialog box.

- 2 Click the **Device Manager** tab.
- 3 To view the device(s) installed, double-click the device type.
- 4 To view the properties, double-click the device.

Windows 98 Second Edition displays the Device Properties dialog box, which provides various tabs from which to choose. Some of the common ones are:

- ❖ The **General** tab, which provides basic information about the device.

- ❖ The **Resources** tab, which lists the resources assigned to the device. If you have a device conflict, it is shown in the Conflicting device list.
- ❖ The **Drivers** tab, which displays the drivers being used by the device.

For more information about Device Manager, refer to Windows 98 Second Edition online help.

Memory card problems

Incorrectly connected or faulty memory cards may cause errors that seem to be device-related. So it is worthwhile checking for these first:

- 1 Click **Start**, then click **Shut Down**.
- 2 Select **Shut down**, then click **OK**.

Windows 98 Second Edition shuts down and turns off the computer automatically.

- 3 Remove the memory card.
- 4 Reinstall the memory card, following the instructions in [Installing additional memory \(optional\) on page 108](#), and making sure it is seated properly.
- 5 Check for the error again.
- 6 If the error recurs, remove the memory card entirely and check for the error again.

If removing the memory card eliminates the error, the memory card may be faulty. If the error recurs without the memory card installed, the error is not caused by the memory card.

Power and the batteries

Your computer receives its power through the AC adapter and power cable or from the system batteries (main battery, optional

High-capacity battery, and real-time clock (RTC) battery). Power problems are interrelated. For example, a faulty AC adapter or power cable will neither power the computer nor recharge the batteries.

Here are some typical problems and how to solve them:

The AC power light does not come on when you plug in the AC adapter and power cable.

Make sure the AC adapter and power cable are firmly plugged into both the wall outlet and the computer.

If the AC power light still does not come on, check that the wall outlet is working properly by plugging in a lamp or other appliance.

The AC adapter and power cable work correctly, but the main battery will not charge.

The main battery doesn't charge while the computer is consuming full power. Try turning off the computer.

The main battery may not be inserted correctly in the computer. Turn off the computer, remove the main battery, clean the contacts with a soft dry cloth (if necessary) and replace the main battery.

The main battery may be too hot or too cold to charge properly. Its temperature needs to be in the range of 50 degrees to 88 degrees Fahrenheit (10 degrees to 30 degrees Celsius). If you think this is the probable cause, let the main battery reach room temperature and try again.

If the main battery has completely discharged, it will not begin charging immediately. Leave the AC adapter and power cable connected, wait 20 minutes and see whether the main battery is charging.

If the main battery light is glowing after 20 minutes, let the computer continue charging the main battery for at least another 20 minutes before you turn on the computer.

If the main battery light does not glow after 20 minutes, the main battery may have reached the end of its useful life. Try replacing it.

The main battery appears not to power the computer for as long as it usually does.

If you frequently recharge a partially charged main battery, it may not charge fully. Let the main battery discharge completely, then try charging it again.

Check the power options using the Windows 98 Second Edition Power Management utility. Have you added a device, such as a PC Card or memory module, that takes its power from the main battery? Is your software using the hard disk more? Is the display power set to turn off automatically? Was the main battery fully charged to begin with? All these conditions affect how long the charge lasts.

For more information on maximizing main battery power, see [Maximizing battery life on page 92](#).

Keyboard problems

When you type, if strange things happen or nothing happens, the problem may be related to the keyboard itself.

The keyboard produces unexpected characters.

A keypad overlay may be on. If the numeric keypad or cursor control light is on, press Fn and F10 simultaneously to turn off the cursor control light or press Fn and F11 simultaneously to turn off the numeric keypad light.

If the problem occurs when both the keypad overlays are off, make sure the software you are using is not remapping the keyboard. Refer to the software's documentation and check that the program does not assign different meanings to any of the keys.

You have connected an external keyboard and Windows 98 Second Edition displays one or more keyboard error messages.

If you have a second keyboard, try it. If it works, the first keyboard may be defective or incompatible with your computer.

Nothing happens when you press the keys on the external keyboard.

You may have plugged an external PS/2 keyboard in while the computer was turned on. Using the AccuPoint II pointing device, click **Start**, then click **Shut Down**. When the Shut Down Windows 98 Second Edition dialog box appears, select **Restart** and click **OK**. The computer will restart and recognize the keyboard.

The keyboard locks and the computer will not restart.

Make sure the power is on and press the reset button.

AccuPoint II problems

Some of the keyboard problems already listed may affect the AccuPoint II. In addition:

Your finger slides off the AccuPoint II easily.

If the AccuPoint II cap is oily, remove the cap and clean it with a cotton swab dipped in rubbing alcohol.

To remove the cap:

- 1** Firmly grasp the cap and pull it straight up.

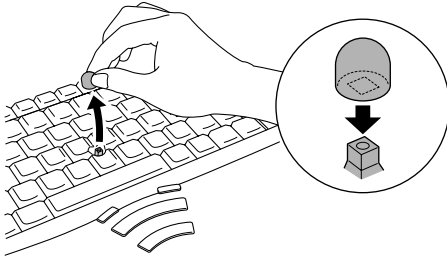

Removing the AccuPoint II cap

- 2 After cleaning the cap, position it on the peg and press it into place.



NOTE: The peg is square, so be careful to align the cap's hole with the peg.

Display problems

Here are some typical display problems and their solutions:

The display is blank.

Display Auto Off may have gone into effect. Press any key to activate the screen.

You may have activated the instant password feature by pressing Fn and F1 simultaneously. If you have registered a password, press Enter, type the password and press Enter. If no password is registered, simply press Enter. The screen reactivates and allows you to continue working.

If you are using the built-in screen, make sure the display priority is not set for an external monitor. To do this, press Fn and F5 simultaneously (once). If this does not correct the problem, press Fn and F5 simultaneously again to return the display priority to its previous setting.

If you are using an external monitor:

- ❖ Check that the monitor is turned on.
- ❖ Check that the monitor's power cable is firmly plugged into a working power outlet.
- ❖ Check that the cable connecting the external monitor to the computer is firmly attached.
- ❖ Try adjusting the contrast and brightness controls on the external monitor.
- ❖ Press Fn and F5 simultaneously to make sure the display priority is not set for the built-in screen.

The screen does not look right.

You can change the display settings by clicking a blank area of the desktop with the AccuPoint II secondary button, then clicking Properties. This causes Windows 98 Second Edition to open the Display Properties dialog box. The Appearance tab of this dialog box allows you to choose the colors for the screen. The Settings tab allows you to choose the screen resolution.

The built-in screen flickers.

Some flickering is a normal result of the way the screen produces colors. To reduce the amount of flickering, try using fewer colors.

A message tells you that there is a problem with your display settings and that the adapter type is incorrect or the current settings do not work with your hardware.

Reduce the size of the color palette to one that is supported by the computer's internal display.

The display mode is set to Simultaneous and the external display device does not work.

Make sure the device is capable of displaying at resolutions of 800 x 600 or higher. Devices that do not support this resolution will only work in Internal/External mode.

Disk drive problems

Problems with the hard disk or with the diskette drive usually show up as an inability to access the disk or as sector errors. Sometimes a disk problem may cause one or more files to appear to have garbage in them. Typical disk problems are:

You are having trouble accessing a disk, or one or more files appear to be missing.

Make sure you are identifying the drive by its correct name (A: or C:).

Run ScanDisk, which analyzes the directories, files and File Allocation Table (FAT) on the disk and repairs any damage it finds:

To run ScanDisk:

- 1** Click **Start**, point to **Programs, Accessories, System Tools**, and click **ScanDisk**.
- 2** Click the drive you want to test.
- 3** Select the type of test you want to use.

A thorough test is more complete but takes much more time than a standard test.

- 4** Click **Start**.

ScanDisk tests the disk.

Your hard disk seems very slow.

If you have been using your computer for some time, your files may have become fragmented. Run Disk Defragmenter. To do this, click **Start**, point to **Programs, Accessories, System Tools**, and click **Disk Defragmenter**.

Your data files are damaged or corrupted.

Refer to your software documentation for file recovery procedures. Many software packages automatically create backup files.

You may also be able to recover lost data using utility software, which is available from your network administrator or your authorized Toshiba representative.

Some programs run correctly but others do not.

This is probably a configuration problem. If a program does not run properly, refer to its documentation and check that the hardware configuration meets its needs.

A disk will not go into the diskette drive.

You may already have a diskette in the drive. Make sure the drive is empty.

You may be inserting the diskette incorrectly. Hold the disk with the hub side facing down, and insert it so that the metal head window cover goes into the drive first.

The metal cover or a loose label may be obstructing the path into the drive. Carefully inspect the diskette. If the metal cover is loose, replace the diskette. If the label is loose, replace the label and try inserting the diskette again.

The computer displays the Non-system disk or disk error message.

If you are starting the computer from the hard disk, make sure there is no diskette in the diskette drive.

If you are starting the computer from a diskette, the diskette in the drive does not have the files necessary to start the computer. Replace it with a bootable diskette.

The drive cannot read a diskette.

Try another diskette. If you can access the second diskette, the first diskette (not the diskette drive) is probably causing the problem.

Run ScanDisk on the faulty diskette (for instructions, see [Disk drive problems on page 197](#)).

DVD-ROM drive problems

DVDEExpress has been configured to provide optimum performance and quality based upon your system's available resources. Changes made to the system or its configuration may impact the playback performance of the DVDEExpress player.

General issues

DVDEExpress controls are disabled.

Controls may be grayed out by commands on the DVD. For example, it is common for DVD movie titles to disable fast-forward and rewind during the legal notices at the beginning of a movie.

Playback performance is poor.

The use of DMA dramatically increases the DVD playback performance of your system.

To make sure DMA is turned on and check its settings:

- 1 Open the **Start** menu, point to **Settings**, then click **Control Panel**.
- 2 Double-click the **System** icon, then select the **Device Manager** tab.
- 3 Open the **CDROM** device folder, select your CD-ROM device driver, then click **Properties**.
- 4 Select the **Settings** tab, click the **DMA** check box, then click **OK**.

The system must be restarted for this setting to take effect.

The “Root” or “Title” menu does not open.

Most DVD titles have one or both of the “Root” and “Title” menus. If one menu button appears to do nothing, try the other menu button.

DVDExpress performance decreases after making a system change.

DVD playback performance is dependent upon several system resources. Changes to these system resources caused, for example, by installing a new graphics or audio card may impact performance. Some software changes may also impact playback performance (for example, downloading new drivers from the Web).

Before installing a new hardware or software component on your system, check for any potential conflicts between its resource requirements and your current system configuration. Also, if you change your Operating System, check with your PC manufacturer or your graphics card vendor to ensure that you have the appropriate drivers for both your hardware (for example, the graphics card) and software (drivers must support the Operating System and DVD with DVDExpress).

Slow playback performance.

DVD playback is a resource intensive application. Other applications and/or changes to your system hardware, software or configuration can impact playback performance. If playback is slower than normal, try the following:

- 1 Close any other open applications to improve the performance of the DVD playback.
- 2 Ensure DMA is turned on. For instructions, see [Playback performance is poor. on page 199](#).
- 3 If you have installed new hardware (such as a new graphics card or audio card), ensure the component’s drivers support

Microsoft DirectX® 5.2b or higher and DVDEExpress. Contact the manufacturer of the component.

- 4 Make sure that your display driver resolution, color depth and refresh rate are optimal for DVD playback. (Some systems do not support video overlays if these parameters are not optimal.) Try lowering these settings to improve performance.

Content issues

Movies exhibit poor performance of “Director's Commentary” or other similar optional content versions.

Some movies may exhibit poor performance of these features. In particular, the video portion of the movie may become jerky or show pauses. The normal version of the movie will not show this problem.

DVDEExpress will not function properly with “debug” software installed.

The DVDEExpress application will not function properly if it detects that debug software is present on the system. Remove the debug software to restore functionality of DVDEExpress.

Minimum system requirements

DVDEExpress performs best when the following recommended components are present in your system:

- ❖ Sound card (with 48 KHz sampling rate support)
- ❖ Windows 95 or higher
- ❖ DirectX Foundation 6.0 or higher (Source: Microsoft)
- ❖ DirectShow® 6.0 (Source: Microsoft)
- ❖ 2x DVD-ROM Drive with DMA enabled (only available with Microsoft OSR 2.1 or above with PIXX 4.0 and USB support added)

- ❖ Mediamatics DVDEExpress software

Error messages

This section provides resolutions for error messages that may appear when using DVDEExpress.

The disc in the DVD-ROM drive is not a valid disc type. Valid disc types are DVD-Video and audio CD.

Ensure the disc is a valid disc type.

If the disc works in other players, try using a disc cleaner.

The disc may require features that are not supported by DVDEExpress.

Microsoft DirectShow components are missing. Microsoft DirectShow is not installed properly on the system.

Reinstall MicrosoftDirectShow version 6.0 or higher (available from the Microsoft Web site).

No audio subsystem could be found for playback.

There is a problem with the audio card or audio component within the system. The problem may be one of the following:

- ❖ There is no audio card
- ❖ The audio card is faulty
- ❖ The wrong audio card is installed in the system
- ❖ There is a problem with the audio driver

Check installation of audio sound card

Check installation of sound card drivers

DVDEExpress cannot display the selected resolution due to system limitations.

The screen size exceeds the allowable display limit. There are not enough system resources to play the DVD at the selected setting.

Alter the display settings to reduce the resolution or number of colors.

Update video drivers.

The audio settings are incorrect. Please check sound card or drivers.

The audio card was found, but there is a problem with the audio card or drivers. The wrong audio card and/or audio driver may be installed in the system.

Check installation of audio sound card.

Check installation of audio card drivers.

An unexpected error has occurred.

This error is unclassified. Report the problem and any error code to your supplier's Technical Support.

This is usually a rare, title-specific problem.

There is a problem with the copy protection system within the DVD-ROM drive. Playback cannot continue.

The DVD-ROM drive failed to authenticate (authorize playback of) the DVD disc. There may be a problem with the DVD-ROM drive.

Try to play another disc. Contact your supplier's Technical Support.

DVDEExpress does not support this version of the DVD specification.

Check that this is a DVD-Video 1.0 disc.

This DVD disc cannot be played in this region.

The selected region cannot be used due to one of the following:

- ❖ The Region Code of DVDEExpress and the DVD disc do not match. Check the Region Code of DVDEExpress within the About tab and use a disc from the appropriate region.
- ❖ The Windows operating system is assigned to a region that does not match the Region Code of DVDEExpress.

Use DVD content from the appropriate region. If applicable on your system, refer to the Help file for how to change the Region Code.

Permission to play is denied. Please check the parental control setting.

The Parental Control setting of DVDEExpress is lower than the Parental Control level of the content being played. Playback of the DVD disc is not authorized.

Change the Parental Control level in the DVD Options dialog. Note that DVDEExpress requires a password for this change.

Playback has stopped due to a Macrovision® copy protection error.

Macrovision prevents unauthorized copying of content. The graphics card driver has notified DVDEExpress of a Macrovision error. This error may indicate a problem with Macrovision and/or the graphics driver.

Reinstall the original graphics driver that came with your system.

Contact your graphics vendor for a driver that supports Macrovision copy protection.

DVDEExpress encountered an error.

Report the problem and any error code to your supplier's Technical Support.

This file appears to contain unsupported data.

Please refer to the Supported Formats section of the DVDEExpress Help file and ensure that this file contains valid data.

The drive or disc cannot be found.

This may be caused by one of the following: No disc in the DVD-ROM drive or No DVD-ROM drive.

A disc of an unsupported type in the DVD-ROM drive.

Check the DVD-ROM drive or DVD disc. Ensure the disc is a valid type (DVD-Video, Video-CD, or audio CD).

Sound system problems

You do not hear any sound from the computer.

Adjust the volume control.

If you are using an external headphone or speakers, check that they are securely connected to your computer.

The computer emits a loud, high-pitched noise.

This is feedback between the microphone and the speakers. It occurs in any sound system when input from a microphone is fed to the speakers and the speaker volume is too loud. Adjust the volume control.

Changing the settings for the Record Monitor feature in the Recording Control Utility (default Off), or the Mute feature in the Mixer Utility (default Enabled), may cause feedback. Revert to the default settings.

PC Card problems

PC Cards (PCMCIA-compatible) include many types of devices, such as a removable hard disk, additional memory, or pager.

Most PC Card problems occur during installation and setup of new cards. If you're having trouble getting one or more of these devices to work together, several sections in this chapter may apply.

Resource conflicts can cause problems when using PC Cards. See [Resolving a hardware conflict on page 187](#).

Card Information Structure

When you insert a PC Card into a slot, the computer attempts to determine the type of card and resources it requires by reading its Card Information Structure (CIS). Sometimes the CIS contains enough information for you to use the card immediately.

Other cards must be set up before you can use them. Use the Windows 98 Second Edition PC Card (PCMCIA) Wizard to set up the card. Refer to your Microsoft documentation for more information, or refer to the documentation that came with the PC Card.

Some card manufacturers use special software called *enablers* to support their cards. Enablers result in nonstandard configurations that can cause problems when installing the PC Card.

If Windows 98 Second Edition does not have built-in drivers for your PC Card and the card did not come with a Windows 98 Second Edition driver, it may not work under Windows 98 Second Edition. Contact the manufacturer of the PC Card for information about using the card under Windows 98 Second Edition.

PC Card checklist

- ❖ Make sure the card is inserted properly into the slot.
See [Using PC Cards on page 126](#) for more information.
- ❖ Make sure all cables are securely connected.
- ❖ Make sure the computer is loading only one version of Card and Socket Services.

- ❖ Occasionally a defective PC Card slips through quality control. If another PCMCIA-equipped computer is available, try the card in that machine. If the card malfunctions again, it may be defective.

Resolving PC Card problems

Here are some common problems and their solutions:

The slots appear to be dead. PC Cards that used to work no longer work.

Check the PC Card status:

- 1** Click the **My Computer** icon with the secondary button, then click **Properties**.

Windows 98 Second Edition displays the System Properties dialog box.

- 2** Click the **Device Manager** tab.

- 3** Double-click the device listed as your PC Card.

Windows 98 Second Edition displays your PC Card's Properties dialog box. This dialog box contains information about your PC Card configuration and status.

The computer stops working (hangs) when you insert a PC Card.

The problem may be caused by an I/O (input/output) conflict between the PCMCIA socket and another device in the system. Use Device Manager to make sure each device has its own I/O base address. See [Fixing a problem with Device Manager on page 189](#) for more information.

Since all PC Cards share the same socket, each card is not required to have its own address.

Hot swapping (removing one PC Card and inserting another without turning the computer off) fails.

Follow this procedure before you remove a PC Card:

- 1 Click the **PC Card** icon on the taskbar.
- 2 Click **Stop xxxx**, where *xxxx* is the identifier for your PC Card.

Windows 98 Second Edition displays a message that you may safely remove the card.

- 3 Remove the card from the slot.

The system does not recognize your PC Card or PCMCIA socket controller.

This problem may be caused by a low main battery. Charge the main battery fully:

- 1 Make sure the computer is not in Standby mode.
- 2 Turn off the computer.
- 3 Connect the AC adapter and power cable.
- 4 Keep the computer plugged in for about three hours with the power turned off.

The problem may also be caused by a conflict with any additional memory in your system.

Removing a malfunctioning card, inserting it again, and reinstalling it using the procedure in [Using PC Cards on page 126](#) can correct many problems.

A PC Card error occurs.

Reinsert the card to make sure it is properly connected.

If the card is attached to an external device, check that the connection is secure.

Refer to the card's documentation, which should contain a troubleshooting section.

Printer problems

This section lists some of the most common printer problems.

The printer will not print.

Check that the printer is connected to a working power outlet, turned on and ready (on line).

Check that the printer has plenty of paper. Some printers will not start printing when there are just two or three sheets of paper left in the tray.

Make sure the printer cable is firmly attached to the computer and the printer.

If your printer is ECP- or IEEE 1284-compliant, make sure you have an IEEE 1284 printer cable.

Run the printer's self-test to check for any problem with the printer itself.

Make sure you installed the proper printer drivers, as shown in [Printing your work on page 69](#).

You may have connected the printer while the computer is on. Turn off the computer and the printer. Turn the printer back on, make sure it is on line, then turn the computer back on.

Try printing another file. For example, you could create and attempt to print a short test file using Notepad. If a Notepad file prints correctly, the problem may be in your original file.

The printer will not print what you see on the screen.

Many programs display information on the screen differently from the way they print it. See if your program has a print preview mode. This mode lets you see your work exactly as it will print. Contact the software manufacturer for more information.

Modem problems

This section lists common modem problems.

The modem will not receive or transmit properly.

Make sure the RJ11 cable (the one on the right side of the computer that goes from the modem to the telephone line) is firmly connected to the computer's modem port and the telephone line socket.

Check the serial port settings to make sure the hardware and software are referring to the same COM port (look in Device Manager under Modems for the built-in modem).

Check the communications parameters (baud rate, parity, data length and stop bits) specified in the communications program. It should be set up to transmit at 300, 1200, 2400, 4800, 9600, 14400, 28800, 33600 bps (bits per second) or higher. Refer to the program's documentation and the modem manual for information on how to change these settings.

The modem is on, set up properly and still will not transmit or receive data.

Make sure the line has a dial tone. Connect a telephone handset to the line to check this.

The other system may be busy or off line. Try making a test transmission to someone else.

Develop good computing habits

Make sure you are prepared.

Save your work frequently.

You can never predict when your computer will lock, forcing you to close a program and lose unsaved changes. Many software programs build in an automatic backup, but you should not rely

solely on this feature. Save your work! See [Computing tips on page 59](#) for instructions.

On a regular basis, back up the information stored on your hard disk.

Here are some ways you can do this:

- ❖ Copy files to diskette in Windows 98 Second Edition, following the steps in [Saving your work on page 67](#)
- ❖ Connect a tape drive to the system and use specialized software to copy everything on the hard disk to a tape
- ❖ Copy files to your network partition

Some people use a combination of these methods, backing up all files to tape or CD weekly and copying critical files to diskette on a daily basis.

If you have installed your own programs, you should back up your programs as well as your data files. If something goes wrong that requires you to format your hard disk and start again, reloading all your programs and data files from a backup will save time.

Read the user's guides.

It's very difficult to provide a fail-safe set of steps you can follow every time you experience a problem with the computer. Your ability to solve problems will improve as you learn about how the computer and its software work together.

Get familiar with all the user's guides provided with your computer, as well as the manuals that come with the programs and devices you use.

Your local computer store or book store sells a variety of self-help books you can use to supplement the information in the manuals.

Use VirtualTech

VirtualTech is a suite of innovative support resources and tools installed on your computer. VirtualTech will make your computing experience easier and more fulfilling by assisting you when you have questions, run into problems, or need help with your computer or programs.



To access VirtualTech, double-click the VirtualTech icon located on your computer's desktop.

Following is a summary of the kinds of resources and tools VirtualTech has to offer:

- ❖ A library of solutions to common computer problems. These are arranged into easy-to-navigate topics like software, hardware and the Internet.
- ❖ A set of powerful support tools that can:
 - ❖ Retrieve hardware and software details whenever you need system configuration information
 - ❖ Provide a real time view of your machine's condition and running applications. VirtualTech can take up to 10 "snapshots" of your applications to ensure you can restore your configuration and replace or repair damaged files
 - ❖ Check and inform you of any updates whenever you go online. To load an update, click **yes**
 - ❖ Run a detailed system report that harvests and compiles your system's hardware and software information. This report is also accessible to Toshiba's InTouch Center technicians to reference when you place a call or send a question electronically
 - ❖ Direct you to Ask IRIS Online™, Toshiba's instant response information service where you can ask questions and receive answers

- ❖ Send a message electronically with your questions directly to our InTouch Center. A representative will address your situation and contact you

If you need further assistance

If you have followed the recommendations in this chapter and are still having problems, you may need additional technical assistance. This section contains the steps to take to ask for help.

Before you call

Since some problems may be related to the operating system or the program you are using, it is important to investigate other sources of assistance first.

Try the following before contacting Toshiba:

- ❖ Review the troubleshooting information in your Windows 98 Second Edition documentation.
- ❖ If the problem occurs while you are running a program, consult the program's documentation for troubleshooting suggestions. Contact the software company's technical support group for their assistance.
- ❖ Consult your network administrator.
- ❖ Consult your authorized Toshiba representative, who is your best source for current information.

Contacting Toshiba

If you still need help and suspect that the problem is hardware-related, Toshiba offers a variety of resources to help you.

- 1 Start with accessing Toshiba on the Internet using any Internet browser by typing:
www.pcsupport.toshiba.com

- 2 Next, try one of Toshiba's online services. The Toshiba Forum can be accessed through CompuServe®.

Toshiba voice contact

Before calling Toshiba, make sure you have:

- ❖ Your computer's serial number
- ❖ The computer and any optional devices related to the problem
- ❖ Backup copies of your Windows operating system and all other preloaded software on diskettes or CD
- ❖ Name and version of the program involved in the problem along with its installation diskettes or CD
- ❖ Information about what you were doing when the problem occurred
- ❖ Exact error messages and when they occurred

For technical support, call the Toshiba InTouch Center:

Within the United States at (800) 457-7777

Outside the United States at (949) 859-4273

Other Toshiba Internet Web sites

www.toshiba.com	Worldwide Toshiba corporate site
www.computers.toshiba.com	Marketing and product information in the USA
www.toshiba.ca	Canada
www.toshiba-Europe.com	Europe
www.toshiba.co.jp/index.htm	Japan

Toshiba's worldwide offices

Argentina

Acron S.A.
Solís 1525
(1134) Buenos Aires
Argentina

Austria

Toshiba Europe GmbH
Niederlassung Österreich
Landstraßer
Hauptstraße 2/259 a - c, A-1030
Wien, Austria

Brazil

Semp Toshiba Informática
Silveria Rodrigues 52
05047-000 Sao Paulo
SP Brazil

Central America & Caribbean

TechData Latin America
8501 NW 17th Street, #101
Miami, FL 33126
United States

Colombia

CHS Promark Colombia Ltda.
Carrera 129, Nro. 2957
Parque Industrial de Occidente
Bodega 30 - Zona Fontibón
Santa Fe de Bogotá, Colombia

Australia

Toshiba (Australia) Pty. Limited
84-92 Talavera Road
North Ryde NSW 2113
Sydney
Australia

Belgium

Toshiba Information Systems Benelux
(Belgium) B.V.
Excelsiorlaan 40
B-1930 Zaventem
Belgium

Canada

Toshiba Canada Ltd.
191 McNabb Street
Markham, Ontario
L3R - 8H2
Canada

Chile

CHS Promark Chile Ltda.
J. Joaquin Aguirre Luco 1339
Huechuraba
Santiago, Chile

Czech Republic

CHG Toshiba, s.r.o.
Hnevkovskeho 65
61700 Brno

Denmark

Scribona Danmark A/S
Naverland 27
DK2600 Glostrup
Denmark

France

Toshiba Systèmes (France) S.A.
7, Rue Ampère
92804 Puteaux Cédex
France

Greece

Ideal Electronics S.A.
109 Syngrou Avenue
176 71 Kalithea
Athens
Greece

Ireland

Same as United Kingdom

Japan

Toshiba Corporation, PCO-IO
1-1, Shibaura 1-Chome
Minato-Ku, Tokyo, 105-8001
Japan

Mexico

Toshiba de Mexico
Paseo de la Reforma no. 30,
4-Piso
Centro 06048 D.F.
Mexico City
Mexico

Finland

Scribona TPC OY
Sinimäentie 14
P.O. Box 83
02630 ESPOO
Finland

Germany

Toshiba Europe GmbH
Leibnizstraße 2
D-93055 Regensburg
Germany

Hungary

Technotrade Kft.
Öv utca 185
1147 Budapest
Hungary

Italy

Progetto Elettronica 92 s.r.l.
Viale Certosa 138,
20156 Milano
Italy

Luxembourg

Same as Belgium

Morocco

C.B.I.
22 Rue de Béthune
Casablanca
Morocco

The Netherlands

Toshiba Information Systems
Benelux B.V.
Rivium Boulevard 41
2909 LK, Capelle a/d IJssel
The Netherlands

Norway

Scribona Norge A/S
Toshiba PC Service
Stalfjaera 20
P.O. Box 51
Kalbakken
0901 OSLO 9
Norway

Poland

TECHMEX S.A.
ul. Partyzantów 71,
43-316 Bielsko-Biala
01-059 Warszawa
Poland

Slovakia

HTC s.r.o.
Kukucinova 26
831 03 Bratislava
Slovakia

Spain

Toshiba Information Systems
(España) S.A.
Parque Empresarial San Fernando
Edificio Europa, 1a Planta
Escalera A
28831 (Madrid) San Fernando de
Henares
Spain

New Zealand

Toshiba (New Zealand) Pty. Limited
Level 4, 3 Ferncroft Street
Grafton Auckland
New Zealand

Papua New Guinea

Fujitsu (PNG) Pty. Ltd.
P.O. Box 4952 Boroko
NCD, Papua
New Guinea

Portugal

Quinta Grande Assistência Técnica
Informática, Lda.
Av. Moinhos no. 15A
Ur. Quinta Grande
2720 Alfragide
Portugal

Slovenia

Inea d.o.o.
Ljubljanska 80
1230 Domzale
Slovenia

Sweden

Scribona PC AB
Sundbybergsväegen 1
Box 1374
171 27 Solna
Sweden

Switzerland

Ozalid AG
Herostrasse 7
8048 Zürich
Switzerland

United States

Toshiba America Information
Systems, Inc.
9740 Irvine Boulevard
Irvine, California 92618
United States

United Kingdom

Toshiba Information Systems
(U.K) Ltd.
Toshiba Court
Weybridge Business Park
Addlestone Road
Weybridge KT15 2UL
United Kingdom

Venezuela

InterPC de Venezuela
Esquina Calle 4 y Calle 8
Edificio Tepal - Piso 3
La Urbina
Caracas 1073 - Venezuela

Appendix A

Hot Keys

Hot keys are keys that, when pressed in combination with the Fn key, turn system functions on and off. Hot keys have a legend on or above the key indicating the option or feature the key controls.

Instant password security

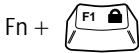

This hot key locks the keyboard and blanks the display. To resume working, if you have registered a user password, press Enter, type your user password, and press Enter. If there is no registered password, simply press Enter. To register a password, see [Setting user passwords on page 171](#).

Power usage mode

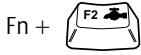

This hot key displays the power usage pop-up window and cycles through the battery usage modes.

The power usage modes under battery power are:
Long Life, Normal, and High Power.

The power usage mode under AC power is Full Power only.

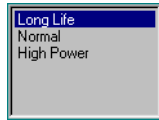

Power usage modes

Shutdown mode

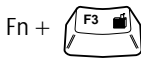

This hot key displays the Shutdown Mode pop-up window and cycles through the options.

If Hibernation mode is enabled (the default) the Shutdown modes are: Standby, Hibernate, and Power Off.

If Hibernate mode is disabled, the choices are: Standby and Power Off. To enable/disable Hibernation mode, see [Setting user passwords on page 171](#).

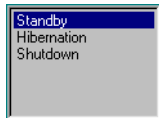

Shutdown modes

Sound

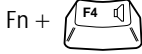

This hot key cycles through the different alarm volume levels.

The alarm volume options are:
off, Low, Medium, and High.

Off is always first.

Display modes

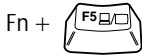

This hot key cycles through the power-on display options.

The display modes are:
built-in display panel only, built-in display panel and external monitor simultaneously, external monitor only, built in display panel and TV (or other external video device) simultaneously, and TV (or other external video device) only.

In order to use a simultaneous mode, you must set the resolution of the internal display panel to match the resolution of the external display device.

Keyboard hot keys

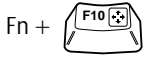

This hot key turns the cursor control overlay on and off.

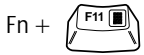

This hot key turns the numeric overlay on and off.

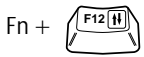

This hot key turns the scroll lock feature on and off.

Appendix B

Features and Specifications

This appendix lists the features of Satellite Pro 4600 series computers and summarizes their specifications.

Features

This section lists the standard features of your Satellite Pro computer.

Technology and processor

Microprocessor	Intel® Mobile Pentium® PIII processor: 750/800/850 MHz
Processor L1 cache	32 KB integrated internal Level 1 cache; 16 KB instruction, 16 KB data
Processor L2 cache	256 KB integrated Level 2 cache
Front Side Bus (FSB) clock speed	100 MHz

Memory	Two dedicated PC100 SDRAM memory module slots, fitted with 128 MB as standard. Memory expandable to 512 MB total For more information, see Memory module sizes on page 109 .
--------	--

Storage capacity

Hard disk	2.5-inch integrated Enhanced IDE drive and controller provides nonvolatile storage for 20.0 GB*. * GB = billion bytes
3.5-inch diskette drive	Accommodates both 1.44 MB, high-density (2HD) and 720 KB, double-density (2DD) diskettes
DVD-ROM drive	5.25-inch 8x (maximum) speed (684.4 KB/s DVD, 4,104 KB/s CD transfer speed), DVD-ROM drive allows you to play DVDs, standard CDs and CD-ROMs Compatibility: DVD-ROM, DVD-R, DVD-RW (read-only), CD-ROM, CD-R, CD-RW (read-only)

Standard hardware

Display panel	14.1-inch or 15.0-inch (measured diagonally), 1024 x 768 resolution, TFT active matrix color display
Video Graphics Controller	Trident XP 64-bit graphics accelerator; 32-bit PCI local bus support; BitBLT hardware, Alpha-blending, Direct3D and OpenGL support Digital Video Accelerator supports YUV color space conversion, scaling, zooming, DirectVideo and DirectMPEG
Video Memory	16 MB SDRAM
Keyboard	85-key keyboard with 12 function keys; dedicated Windows keys; includes embedded numeric and cursor control overlays and dedicated cursor control keys
Pointing device	AccuPoint II pointing device provides the complete function of a mouse or other pointing device from within the keyboard
PC Card slots	Two stacked PC Card slots let you install one Type III, or up to two Type I or Type II PC Cards; 32-bit CardBus-ready
Sound controller	Yamaha® YMF743 sound support, Windows Sound System and Sound Blaster Pro® compatible 16-bit stereo with MIDI, 3D Sound, DirectMusic, and Direct 3D Sound Support. Audio output directed to built-in stereo speakers or the headphone jack. Audio input directed from specified software file or the microphone jack

Communications	<p>Integrated V.90 56K modem</p> <p>Due to FCC limitations, speeds of 53kbps are the maximum permissible transmission rates during downloads. Actual data transmission speeds will vary depending on line conditions.</p>
Networking	<p>Integrated Intel ProSet 10/100 Base-TX Ethernet LAN adapter with RJ45 port</p> <p>For systems with a PIII 750 MHz or PIII 800 MHz processor, the computer is wireless ready with a built-in antenna. Using this functionality requires an optional Wi-Fi module.</p> <p>For systems with a Pentium PIII 850 MHz processor, the computer comes with an integrated Wi-Fi 802.11b wireless LAN mini PCI communication module providing wireless LAN functions that support Ethernet LAN (10/100 Base-T).</p>
Warranty	1 year parts and labor; 1 year battery

Ports

Serial port	9-pin, RS-232C-compatible high-speed buffered 16550UART-compatible serial port lets you connect a serial mouse, serial printer or other serial device
Parallel port	An IEEE 1284 8-bit Enhanced Capability Port (ECP) for connecting a parallel device such as a printer. It provides increased performance when used with an ECP-compatible device
Video-out port	SVGA port for connecting an external monitor
Television jack	RCA jack for NTSC/PAL video signal to connect to an external television

PS/2 port	<p>PS/2-compatible port lets you connect a full-size keyboard or a PS/2 mouse.</p> <p>You can purchase a “Y” cable that allows you to connect a PS/2 keyboard and a PS/2 mouse simultaneously</p>
Expansion port	<p>240-pin port allows you to connect an optional expansion device</p>
IrDA port	<p>IrDA 1.1 compliant, fast infrared port supports 4Mbps transfer rate with IrDA 1.1 compatible external devices</p>
USB port	<p>Two Universal Serial Bus ports provide connections for USB peripherals, such as a USB mouse or keyboard</p>
Modem port	<p>RJ11 port allows you to connect your modem to the telephone line</p>
LAN port	<p>RJ45 port allows you to connect your Ethernet adapter to a network</p>
Microphone jack	<p>3.5 mm jack lets you connect an external microphone or other monaural audio input device</p>
Headphone jack	<p>3.5 mm jack lets you connect stereo headphones or other audio output devices, such as external speakers</p>

Power and batteries

AC Power	External universal AC power adapter 100-240V, 50-60 Hz, 60W
Main Battery	<p>Removable, rechargeable Li-ion battery pack provides 10.8V x 4000 mAh output</p> <p>Battery life is approximately 2.5 hours in normal mode. Actual battery life will vary depending on applications, power management settings and features used</p> <p>Battery recharge time is 3.0 - 4.0 hours if the computer is off, and up to 10.0 hours if the computer is on.</p> <p>Battery life and charge time may vary depending on applications, power management settings, and features used.</p>
RTC battery	Internal NiMH battery provides power for the internal real-time clock and calendar
Automatic power off features	Save battery power by automatically turning off the display, hard disk and system when they have not been accessed for a set length of time

Specifications

Physical dimensions

Weight	
14.1-inch screen models	6.9 lbs. (3.17 kg)
15.0-inch screen models	7.4 lbs. (3.37 kg)
	(Weight will vary with installed options)

Dimensions (W x D x H)

14.1-inch screen models	12.6 x 10.8 x 1.8 inches (32.1 x 27.5 x 4.7 cm)
15.0-inch screen models	12.9 x 10.8 x 1.9 inches (32.7 x 27.5 x 4.9 cm)

Environmental conditions

	<i>Operating</i>	<i>Non-operating</i>
Temperature	41 to 95 degrees F (5 to 35 degrees C)	-4 to 149 degrees F (-20 to 65 degrees C)
Relative Humidity	20 to 80 percent non-condensing	10 to 90 percent non-condensing
Altitude (relative to sea level)	-197 to 9,842 feet (-60 to 3,000 meters)	-197 to 32,808 feet (-60 to 10,000 meters)
Shock	10 G	60 G (14.1-inch screen) 40 G (15.0-inch screen)
Vibration	0.50 G	1 G

Optional accessories and devices

This section lists some of the options and accessories available for your computer. To order parts or accessories, see the accessories information packaged with your computer, or visit

www.toshibaaccessories.com.

Memory modules

64 MB memory	64 MB PC100 SDRAM memory module
128 MB memory	128 MB PC100 SDRAM memory module

256 MB memory

256 MB PC100 SDRAM memory module

Power devices

Universal AC adapter

Powers the computer from many different AC power sources

Battery charger

Charges the battery pack

Additional battery packs

Use as spare or replacement packs to extend the time you can operate the computer away from a live wall outlet

Other

Carrying case

Sturdy fabric or leather carrying case protects the computer while traveling

Security

PORT-Noteworthy
Cable Lock

Allows you to secure your computer and deter theft

Appendix C

Power Cable Connectors

The computer features a universal power supply you can use worldwide. This appendix shows the shapes of the typical AC power cable connectors for various parts of the world.

USA and Canada



UL approved
CSA approved

United Kingdom

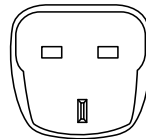

BS approved

Australia



AS approved

Europe



VDA approved
NEMKO approved

— Blank Page —

Appendix D

Video Modes

This appendix lists the video modes supported by the computer display adapter, and identifies the characteristics of each mode.

The columns of the following tables are defined as follows:

Type identifies the display adapter that first supported the mode, and specifies whether the mode is text or graphics.

Resolution is the measure of the screen's dimensions in terms of horizontal and vertical pixels (in graphics modes), or rows and columns of characters (in text modes).

LCD Colors is the maximum number of simultaneous colors, or shades of gray, that the mode can display on the built-in screen.

CRT Colors is the maximum number of simultaneous colors, or shades of gray, that the mode can display on an external monitor.

Max Vertical Refresh Rate is the scanning frequency in Hertz. This is for external monitors only.

This table lists the video modes for your computer:

<i>Type</i>	<i>Resolution</i>	<i>LCD colors</i>	<i>CRT Colors</i>	<i>Max Vertical Refresh Rate (CRT)</i>
VGA	640 x 480	16/256/64K/16M	16/256/64K/16M	60/75/85Hz non-interlaced @ 16M colors
XGA	800 x 600	256/64K/16M	256/64K/16M	60/75/85Hz non-interlaced @ 16M colors
XGA	1024x 768	256/64K/16M	256/64K/16M	60/75/85Hz non-interlaced @ 16M colors
XGA	1280x 1024	256/64K/16M (virtual display)	256/64K/16M	60Hz non-interlaced @ 16M colors
XGA	1400x 1050	256/64K/16M (virtual display)	256/64K/16M	60Hz non-interlaced @ 64K colors
XGA	1600x 1200	256/64K (virtual display)	256/64K/	60Hz non-interlaced @ 64K colors

Glossary



TECHNICAL NOTE: Some features defined in this glossary may not be available on your computer.

Acronyms

The following acronyms may appear in this user's guide.

AC	alternating current
BIOS	basic input/output system
bps	bits per second
CD	compact disc
CD-ROM	compact disc read-only memory
CD-RW	compact disc rewrite memory
CMOS	complementary metal-oxide semiconductor
COM1	communications port 1 (serial port)
COM2	communications port 2 (serial port)
CPU	central processing unit

DC	direct current
DMA	direct memory access
DIMM	dual inline memory module
DOS	disk operating system
DPI	dots per inch
DSTN	dual supertwist nematic
DVD	digital versatile (or video) disc
DVD-ROM	digital versatile (or video) disc read-only memory
ECP	enhanced capabilities port
EPROM	erasable programmable read-only memory
FAT	file allocation table
FCC	Federal Communications Commission
FIR	fast infrared
GB	gigabyte
HDD	hard disk drive
HTML	Hypertext Markup Language
IEEE	Institute of Electrical and Electronics Engineers
I/O	input/output
IRQ	interrupt request
ISP	Internet service provider
KB	kilobyte
LAN	local area network
LCD	liquid crystal display
LPT1	line printer port 1 (parallel port)
LSI	large-scale integration
MB	megabyte
MIDI	Musical Instrument Digital Interface
PC	personal computer
PCI	Peripheral Component Interconnect
PCMCIA	Personal Computer Memory Card International Association

RAM	random access memory
RFI	radio frequency interference
ROM	read-only memory
RTC	real-time clock
SCSI	small computer system interface
SDRAM	synchronous dynamic random access memory
SRAM	static random access memory
SVGA	super video graphics adapter
TFT	thin film transistor
USB	universal serial bus
URL	uniform resource locator
WAN	wide area network
www	World Wide Web

Terms

The following terms may appear in this user's guide.

A

active-matrix display — A liquid crystal display (LCD) made from an array of liquid crystal cells using active-matrix technology. Also known as a “TFT display,” in its simplest form there is one thin film transistor (TFT) for each cell. This type of display works well with notebook computers because of its shallow depth and high-quality color. Active-matrix displays are viewable from wider angles than most passive-matrix displays.

adapter — A device that provides a compatible connection between two units. For example, the computer's internal display adapter receives information from the software and translates it into images on the screen. An adapter can take a number of forms, from a microprocessor to a simple connector. An intelligent adapter (one that is capable of doing some processing) may also be called a controller.

alternating current (AC) — The type of power usually supplied to residential and commercial wall outlets. AC reverses its direction at regular intervals. Compare *direct current (DC)*.

application — A computer program that you use to perform tasks of a specific type. Applications include word processors, spreadsheets, and database management systems. See also *program*.

B

backup — A copy of a file, usually on a removable disk, kept in case the original file is lost or damaged.

basic input/output system (BIOS) — See *BIOS*.

baud rate — The speed at which a communication device, such as a printer or modem, transmits information. Baud rate is the number of signal changes per second (not necessarily the same as bits per second). See also *bits per second*.

BIOS (basic input/output system) — Basic instructions, stored in read-only memory (ROM), containing the information the computer needs in order to check hardware and load the operating system when you start up the computer.

bit: — Short for “binary digit.” A bit is the smallest unit of information used by a computer. A group of eight bits is a byte. See also *byte*.

bits per second (bps) — A way of measuring the speed at which information is passed between two devices. The basic measure used in modem communications, bps is similar, but not identical, to the baud rate. See also *baud rate*.

boot — To start the computer. The term “boot” originates from bootstrap program (as in “pulling itself up by its bootstraps”), a program that loads and initializes the operating system. See also *reboot*.

boot disk — See *system disk*.

boot priority (startup sequence) — The order in which the computer accesses its disk drives to locate the startup files. Under the default startup sequence, the computer looks for the startup files in the diskette drive before checking the hard disk.

bus — An electrical circuit that connects the central processing unit (CPU) with other parts of the computer, such as the video adapter, disk drives, and ports. It is the pathway through which data flows from one device to another. See also *bus speed*, *frontside bus*.

bus speed — The speed at which the central processing unit (CPU) communicates with the other parts of the computer.

byte — A sequence of eight bits. A byte is the smallest addressable unit of data. See also *bit, gigabyte, kilobyte, megabyte*.

C

cache — A section of very fast memory in which frequently used information is duplicated for quick access. Accessing data from cache is faster than accessing it from the computer's main memory. See also *CPU cache, L1 cache, L2 cache*.

CD — An individual compact disc. See also *CD-ROM*.

CD-ROM (compact disc read-only memory) — A form of high-capacity storage that uses laser optics instead of magnetic means for reading data. See also *CD*. Compare *DVD-ROM*.

central processing unit (CPU) — The chip that functions as the “brain” of the computer. It takes information from outside sources, such as memory or keyboard input, processes the information, and sends the results to another device that uses the information.

character — Any letter, number, or symbol you can use on the computer. Some characters are non-printing characters, such as a paragraph break in a word-processing program. A character occupies one byte of computer storage.

chip — A small piece of silicon containing computer logic and circuits for processing, memory, input/output, and/or control functions. Chips are mounted on printed circuit boards.

click — To press and release the AccuPoint control button or mouse button without moving the AccuPoint or mouse. In Windows, this refers to the left mouse button or primary AccuPoint control button, unless otherwise stated. See also *double-click*.

color palette — A set of specified colors that establishes the colors that can be displayed on the screen at a particular time.

compatibility — The extent to which computers, programs, or devices can work together harmoniously, using the same commands, formats, or language as another.

configuration — (1) The collection of components that make up a single computer system. (2) How parts of the system are set up (that is, configured).

controller — A device that controls the transfer of data from a computer to a peripheral device and vice versa. For example, disk drives, monitors, keyboards, and printers all require controllers.

CPU — See *central processing unit (CPU)*.

CPU cache — A section of very fast memory residing between the CPU and the computer's main memory that temporarily stores data and instructions the CPU will need to execute commands and programs. See also *cache, L1 cache, L2 cache*.

cursor — A symbol that indicates the current position on the screen. The shape of the cursor varies, depending on the program you're using and what you're doing.

D

default — The setting selected by a program when the user does not specify an alternative setting.

device — A component attached to the computer. Devices may be external (outside the computer's case) or internal (inside the computer's case). Printers, disk drives, and modems are examples of devices.

device driver — A program (called a "driver") that permits a computer to communicate with a device.

dialog box — An on-screen window displayed by the operating system or a program giving a direction or requesting input from the user.

direct current (DC) — The type of power usually supplied by batteries. DC flows in one direction. Compare *alternating current (AC)*.

direct memory access (DMA) — A dedicated channel, bypassing the CPU, that enables direct data transfer between memory and a device.

directory — See *folder*.

disable — To turn a computer option off. See also *enable*.

disc — A round, flat piece of metal, designed to be read from and written to by optical (laser) technology, and used in the production of optical discs, such as CDs and DVDs. Compare *disk*.

disk — A round, flat piece of material that can be magnetically influenced to hold information in digital form, and used in the production of magnetic disks, such as diskettes and hard disks. Compare *disc*. See also *diskette, hard disk*.

disk drive — The device that reads and writes information and programs on a diskette or hard disk. It rotates the disk at high speed past one or more read/write heads.

diskette — A thin, flexible disk in a protective jacket that stores magnetically encoded data. Diskettes can be removed from the computer and come in two sizes: 5.25-inch and 3.5-inch. Your computer uses 3.5-inch diskettes. See also *double-density diskette*, *high-density diskette*.

document — Any file created with an application and, if saved to disk, given a name by which it can be retrieved. See also *file*.

double-click — To press the AccuPoint control button or mouse button rapidly twice without moving the AccuPoint or mouse. In Windows, this refers to the primary AccuPoint control button or left mouse button, unless otherwise stated.

double-density diskette — A 3.5-inch diskette that can hold up to 720 KB of information (half the capacity of a high-density diskette). See also *diskette*, *high-density diskette*.

download — (1) In communications, to receive a file from another computer through a modem or network. (2) To send font data from the computer to a printer. See also *upload*.

drag — To hold down the AccuPoint control button or mouse button while moving the cursor to drag a selected object. In Windows, this refers to the primary AccuPoint control button or left mouse button, unless otherwise stated.

driver — See *device driver*.

DVD — An individual digital versatile (or video) disc. See also *DVD-ROM*.

DVD-ROM (digital versatile [or video] disc read-only memory) — A very high-capacity storage medium that uses laser optics for reading data. Each DVD-ROM can hold as much data as several CD-ROMs. Compare *CD-ROM*.

E **emulation** — A technique in which a device or program imitates another device or program.

enable — To turn on a computer option. See also *disable*.

executable file — A computer program that is ready to run. Application programs and batch files are examples of executable files. Names of executable files usually end with a .bat or .exe extension.

expansion device — A device that connects to a computer to expand its capabilities. Other names for an expansion device are port expander, port replicator, docking station, or network adapter.

extension — See *file extension*.

external device — See *device*.

F

file — A collection of related information, saved on disk with a unique name. A file may be a program, information used by a program, or a document. See also *document*.

file allocation table (FAT) — The section of a disk that keeps track of the location of files stored on the disk.

file name — A set of characters that uniquely identifies a file within a particular folder. It consists of two parts: the actual name and the file name extension. See also *file extension*.

file extension — The three characters following the period (pronounced “dot”) at the end of a file name. The extension indicates the type of file. Examples are .exe for program files and .hlp for help files. See also *file name*.

folder — Also called directory. A container for organizing files saved to a disk. A folder is symbolized on screen by a graphical image (icon) of a file folder. A folder can contain files and other folders.

format — (verb) To prepare a blank disk for use with the computer’s operating system. Formatting creates a structure on the disk so the operating system can write information to the disk or read information from it.

frontside bus — The primary pathway (bus) between the CPU and the computer’s main memory. Also called “system bus.” See also *bus*.

function keys — The keys labeled F1 through F12, typically located on the keyboard. Their function is determined by the operating system and/or individual programs.

G

gigabyte (GB) — A unit of data equal to 1,073,741,824 bytes (1024 x 1024 x 1024 bytes). See also *byte*.

ground — A conductor to which all components of an electric circuit are connected. It has a potential of zero (0) volts, is connected to the earth, and is the point of reference for voltages in the circuit.

- H** **hard disk** — A storage device composed of a rigid platter or platters that can be magnetically coded with data. Hard disks hold much more information than diskettes and are used for long-term storage of programs and data. The primary (or only) hard disk in a computer is usually fixed, but some computers have secondary hard disks that are removable. By default, the hard disk is referred to as drive C.
- hardware** — The physical components of a computer system. Compare *software*.
- Hibernation** — A feature of many Toshiba notebook computers that saves to the hard disk the current state of your work, including all open files and programs, when you turn the computer off. When you turn on the computer again, your work is returned to the same state it was when the computer was turned off. See also *Standby*, *Suspend*.
- high-density diskette** — A 3.5-inch diskette that holds 1.44 MB of data. See also *diskette*.
- hot key** — (1) A feature in which certain keys in combination with the Fn key can set system options or control system parameters, such as the battery save mode. (2) A key or combination of keys that activates a memory resident program.
- hot swapping** — The ability to add or remove devices from a computer while the computer is running and have the operating system automatically recognize the change.
- I** **icon** — A small image displayed on the screen that represents a function, file, or program.
- interlaced** — A method of refreshing a computer screen, in which only every other line of pixels is refreshed. Interlaced monitors take two passes to create a complete screen image. Compare *non-interlaced*.
- internal device** — See *device*.
- Internet** — The decentralized, world-wide network of computers that provides electronic mail, the World Wide Web, and other services. See also *World Wide Web*.
- K** **keyboard shortcut** — A key or combination of keys that you use to perform a task instead of using a pointing device such as the AccuPoint.
- kilobyte (KB)** — A unit of data equal to 1024 bytes. See also *byte*.

L

- L1 (level one) cache** — Memory cache built into the processor to help improve processing speed. See also *cache*, *CPU cache*, *L2 cache*.
- L2 (level two) cache** — Memory cache installed on the motherboard to help improve processing speed. It is slower than L1 cache and faster than main memory. See also *cache*, *CPU cache*, *L1 cache*.
- LAN (local area network)** — A group of computers or other devices dispersed over a relatively limited area and connected by a communications link that enables any device to interact with any other on the network.
- liquid crystal display (LCD)** — A type of display that uses a liquid substance between two transparent electrode panels. When an electric current passes through the electrodes, the molecules in the liquid form a crystalline pattern that polarizes the light passing through it. A filter over the electrodes permits only non-polarized light to pass to the surface of the display, creating light and dark pixels.
- load** — To move information from a storage device (such as a hard disk) into memory for processing.
- local area network** — See *LAN*.
- logical drive** — A section of a disk that is recognized by the operating system as a separate disk drive. A system's logical drives may differ from its physical drives. For example, a single hard disk drive may be partitioned into two or more logical drives.

M

- megabyte (MB)** — A unit of data equal to 1,048,576 bytes (1024 x 1024 bytes). See also *bytes*.
- memory** — Typically refers to the computer's main memory, where programs are run and data is temporarily stored and processed. Memory can be volatile and hold data temporarily, such as RAM, or it can be nonvolatile and hold data permanently, such as ROM. A computer's main memory is RAM. See *RAM*, *ROM*.
- microprocessor** — See *central processing unit (CPU)*.
- MIDI (Musical Instrument Digital Interface)** — A standard for connecting musical instruments, synthesizers, and computers. The MIDI standard provides a way of translating music into a form computers can use, and vice versa.

modem — Short for “modulator/demodulator.” A device that converts information from digital to analog and back to digital, enabling information to pass back and forth between digital computers and analog telephone lines.

motherboard — The main circuit board in the computer. It contains the processor, memory, and other primary components.

MS-DOS prompt — See *system prompt*.

multimedia — A combination of two or more media, such as sound, animation, and video in a computer program or presentation.

Musical Instrument Digital Interface — See MIDI.

N

network — A collection of computers and associated devices that are connected by communications facilities. A network allows you to share data and peripheral devices, such as printers, with other users and to exchange electronic mail.

non-interlaced — A method of refreshing a computer screen, in which each pixel of every line is refreshed as the electron beam scans across and down the screen. Compare *interlaced*.

non-system disk — A disk for storing programs and data that cannot be used to start the computer. Compare *system disk*.

O

online — Available through the computer. Online may refer to information being read from your own computer’s hard disk, such as online documentation or online help, or to information coming from another company on a company network or the Internet.

operating system — A set of programs that controls how the computer works. Examples of operating systems are Windows 98 Second Edition and Windows 2000.

P

palette — See *color palette*.

parallel — Processes that occur simultaneously. In communications, it means the transmission of more than one bit of information at a time. On your computer, the parallel port provides a parallel communications interface between the computer and an appropriate device. Most modern printers are parallel. Compare *serial*.

password — A unique string of characters entered by a user to verify his or her identity to the computer or the network.

PC Card — A credit-card-sized expansion card designed to increase the capabilities of notebook computers. PC Cards provide functions such as modem, fax/modem, hard disk drive, network adapter, sound card, or SCSI adapter.

peripheral — Any device, such as a printer or joystick, that is attached to the computer and controlled by the computer's CPU.

pixel — Short for "picture element." The smallest dot that can be produced on a screen or printer.

Plug and Play — Generally, refers to the computer's ability to automatically configure itself to work with peripheral devices. When capitalized, refers to a standard that, when followed by a device manufacturer, allows a PC to configure itself automatically to work with the device.

pointing device — Any device, such as the AccuPoint or a mouse, that enables you to move the cursor on the screen.

port — A socket on the computer where you plug in a cable for connection to a network or a peripheral device.

processor — See *central processing unit (CPU)*.

program — A set of instructions that can be executed by a computer. The general classes of programs (also called software) are operating system, application, and utility. See also *operating system*, *application*, *utility*.

properties — The attributes of an object or device. For example, the properties of a file include the file's type, size, and creation date.

R

RAM (random access memory) — Volatile memory that can be written to as well as read. By volatile, we mean that information in RAM is lost when you turn off your computer. This type of memory is used for your computer's main memory. See also *memory*. Compare *ROM*.

random access memory — See *RAM*.

read-only memory — See *ROM*.

reboot — See *boot*, *restart*.

removable disk — A disk that can be removed from a disk drive. A diskette is one example of a removable disk.

resolution — A measure of the sharpness of the images that can be produced by a printer or displayed on a screen. For a printer, resolution is expressed in dots per inch (dpi). For a screen, it is expressed as the number of pixels available horizontally and vertically.

restart — Synonymous with reboot. To reset the computer by reloading the operating system without turning the computer off. See also *boot*.

RJ11 — A modular connector used on most U.S. telephone systems and direct-connect modems. The RJ11 connector is a 6-wire connector.

ROM (read-only memory) — Non-volatile memory that can be read but not written to. By non-volatile, we mean that information in ROM remains whether or not the computer is receiving power. This type of memory is used to store your computer's BIOS, which is essential instructions the computer reads when you start it up. See also *BIOS, memory*. Compare *RAM*.

S

select — To highlight or otherwise specify text, data, or graphics with the intent to perform some operation on it.

serial — Processes that occur one at a time. In communications, it means the transmission of one bit at a time sequentially over a single channel. On your computer, the serial port provides a serial interface between the computer and an appropriate device. Compare *parallel*.

shortcut — See *keyboard shortcut*.

software — See *program*. Compare *hardware*.

Standby — A feature of some Windows operating systems that allows you to turn off the computer without exiting your open applications and to continue from where you left off when you turn the computer on again.

Suspend — A feature of some Windows operating systems that allows you to turn off the computer without exiting your open applications and to continue from where you left off when you turn the computer on again.

system disk — A diskette that contains the operating system files needed to start the computer. Any diskette can be formatted as a system disk. A system disk is also called a “bootable disk” or a “startup disk.” Compare *non-system disk*.

system prompt — The symbol (in MS-DOS, generally a drive letter followed by a “greater than” sign) indicating where users are to enter commands.

**T
U**

TFT display — See *active-matrix display*.

universal serial bus (USB) — A serial bus that supports a data transfer rate of up to 12 Mbps (12 million bits per second). USB can connect up to 127 peripheral devices through a single all-purpose USB port. USB allows hot swapping of peripherals. See also *bus*, *hot swapping*, *serial*.

upload — To send a file to another computer through a modem or network. See also *download*.

USB — See *universal serial bus (USB)*.

utility — A computer program designed to perform a narrowly focused operation or solve a specific problem. Utilities are often related to computer system management.

W

Web — See *World Wide Web*.

Wi-Fi — A trademarked term by the Wireless Capability Ethernet Alliance which stands for Wireless Fidelity. Wi-Fi is another term for the IEEE 802.11b communication protocol to permit an Ethernet connection using wireless communication components.

World Wide Web (www) — The worldwide network of Web sites linked together over the Internet. A user of the Web can jump from site to site regardless of the location of the computer hosting the site. See also *Internet*.

Index

A

- AC adapter 46
- AC power cable connectors 231
- AC power indicator 49
- AC power light 37
- accessories
 - carrying case 230
 - computer lock 230
 - PORT-Noteworthy computer lock 33
- AccuPoint II
 - replacing the cap 194
- alarm
 - closing display panel 166
 - critical battery 102
 - low battery 102
 - volume 166
- audio
 - .wav files 143
- audio features 142

B

- battery 92

- additional packs 93
- alarms 102
- charge indicator light 95
- charging 54
- charging before use 44, 93
- charging RTC 94
- conserving power 97
- critical alarm 102
- indicator 38, 49
- inserting 104
- low charge 97
- maximizing life 92
- monitoring power 95
- optional charger 95
- power usage modes 220
- replacing 102
- safe disposal 105
- safety precautions 93

buttons

- power 33
- reset 32

C

- caps lock 36

- light 36
 - CD player control panel 143
 - CDs
 - care of 77
 - playing audio CDs 142
 - viewing contents 149
 - cleaning the computer 56
 - communications
 - network connection 79
 - setting up 79
 - configuration management tool 166
 - configuring
 - PC Cards 129
 - cursor control overlay 37, 63
- D**
- desktop
 - major features 131
 - Device Manager
 - check/change device properties 189
 - disabling a device 189
 - Direct Memory Access (DMA) 188
 - diskette drive 30
 - diskettes
 - caring for 71
 - inserting and removing 70
 - display panel 35
 - adjusting 34
 - alarm when closing 166
 - automatic power off 101
 - closing 55
 - opening 28, 34
 - screen saver 101
 - DMA assignments 188
 - DVD Player
 - controls and indicators 153
 - status display window 152
 - DVDEExpress
 - error messages 202
 - launching 151
 - minimum system requirements 201
 - play status 152
 - playing a DVD 146
 - playing files 147
 - region coding 158
 - shortcut keys 156
 - DVD-ROM drive 151
 - eject button 73
 - inserting DVDs or compact discs 73
 - manual eject 73
 - reading CDs 151
 - reading DVDs 151
 - removing compact discs or DVDs 76
 - DVDs
 - care of 77
 - viewing contents 149
- E**
- ergonomics 42
 - avoiding arm/wrist strain 43
 - expansion port 29, 130
 - external display
 - adjusting 125
- F**
- features and specifications 223
 - file extensions 69
 - file names
 - MS-DOS 69
 - files
 - backing up 78
 - printing 70
 - restoring 78
 - saving 67
 - Fn-esse program 160
 - assigning a key 160

- using drag-and-drop 161
- using the keyboard or pointing device 162
- changing/removing key assignments 164
- function keys 61

H

- hard disk drive
 - backing up 211
- hardware conflicts
 - DMA assignments 188
 - Interrupt ReQuest (IRQ) Channel 188
 - Plug and Play 188
 - resolving 187, 189
- Hardware Setup 166
 - boot priority 166
 - display settings 166
 - PC Card 166
 - SecureSleep 166
- headphone jack 31
- headphones
 - connecting 145
- Hibernation mode 85, 86, 97
 - default 97
- hot key
 - alarm volume 221
 - display modes 221
 - external display output settings 124
 - instant password security 219
 - keyboard overlays 222
 - power usage mode 220
 - power usage modes 100
 - Shutdown mode 220
 - sound 221
- hot swapping 129
 - precautions 129

I

- icons 24, 132
 - definitions 24
 - Windows 98 Second Edition desktop 132
- indicator
 - AC power 49
 - battery 49
 - cursor control overlay 37
 - DVD-ROM drive 72
 - power on/off 49
- infrared port 31
- installing
 - memory modules 108
- Interrupt ReQuest (IRQ) Channel 188

K

- keyboard
 - caps lock 36
 - caps lock light 36
 - character keys 61
 - Ctrl, Fn, and Alt keys 61
 - cursor control mode light 37, 63
 - emulating a full-size keyboard
 - 150
 - external 114
 - full-size 114
 - function keys 61
 - hot keys 222
 - numeric mode light 37, 63
 - numeric overlay 63
 - overlay keys 62
 - special function keys 62

L

- lighting 43
- lock
 - PORT-Noteworthy computer lock 33
 - security lock slot 33

M

- memory
 - adding 108
 - installing a module 110
 - removing a module 113
- memory cards
 - troubleshooting problems 191
- modem
 - connecting to telephone line 44
- modem port 227
- modes
 - Hibernation 85
 - Safe, Windows 98 Second Edition 183
 - Standby 87
- monitor
 - connecting 122
 - connecting external 123
 - external, connecting 108
- monitor port 29

N

- network
 - accessing 79
 - Dial-Up Networking Wizard 79
- numeric keypad overlay 63
- numeric overlay 37

O

- on/off indicator 49
- optional devices 107
 - battery charger 230
 - LapLink cable 137
 - Universal AC adapter 230
- overlay
 - cursor control 37

P

- parallel port 29
- parallel printer

- connecting 108
- password
 - instant 171
 - how to use 172
 - power-on 171
 - supervisor 171
 - delete 175
 - set up 173
 - supported types 171
- password security, instant 219
- PC Card
 - configuring 129
 - eject button 32
 - enablers 206
 - hot swapping 129
 - inserting 126
 - lock 32
 - removing 128
 - setting up 129
 - troubleshooting 206
- PC Card slot 32, 126
 - types 126
- physical dimensions 228
- Plug and Play 188
- port
 - expansion 29, 130
 - infrared 31
 - monitor 29
 - parallel 29
 - PS/2 29
 - Universal Serial Bus 30
 - video 29
- power
 - automatic power off 228
 - on/off light 37
 - preset usage modes 98
 - universal power supply 231
- power button 33
 - lock 33
- power button lock 49
- power button on/off indicator 49

- power off 82
 - alternate methods 55
 - guidelines 54
 - options 82
 - Shut down command 82
- Power Saver Utility 99
- power usage modes
 - preset 98
- powering down
 - using Hibernation 86
 - using Shut down 82
 - using Standby 88
- powering down the computer 82
- precautions 48
- printer
 - choosing a driver 119
- printing a file 70
- problems See *troubleshooting*
- program
 - starting 64
- PS/2
 - port 29
 - PS/2-compatible keyboard 114
- PS/2 keyboard
 - external, connecting 108
- PS/2 mouse
 - connecting 108
 - working with AccuPoint 116

R

- real-time clock battery
 - recharging 94
- recording
 - .wav files 143
 - sounds 143
- registration, online 54
- reset button 32
- RTC battery See *real-time clock battery*

S

- safety precautions 24
- saving files 67
- ScanDisk program 197
- security
 - lock slot 57
 - locking cable 57
 - PORT-Noteworthy computer lock 33
- serial mouse
 - connecting 108
- serial port 29
- setting up your computer 44
- Shut down command 82
- Shutdown mode
 - hot key 220
- shutting down the computer 82
- sound recording 144
- SPANWorks 80
- speakers 28
 - connecting external 145
- specifications
 - diskette and disk drives 224
 - headphone jack 227
 - IrDA port 227
 - keyboard 225
 - main battery 228
 - microphone jack 227
 - modem 226
 - parallel port 226
 - PC Card slots 225
 - PS/2 port 227
 - real-time clock battery 228
 - serial port 226
- Standby command 87, 88
- Standby mode
 - automatic 97
- starting a program
 - from Run dialog box 66
 - from Windows Explorer 65

- from Windows Start menu 65
- starting up the computer
 - from Shut down 85
 - from Standby 90
- status lights 28
- Step-by-step confirmation 184
- system indicator panel 28

T

- television
 - adjusting display 125
 - connecting 122
- Television jack 226
- television jack 29
- Toshiba online resources 90
- Toshiba online services
 - Toshiba Forum 214
- Toshiba utilities 159
- transferring files 137
- transferring information between
 - computers 137
- troubleshooting 177
 - AC/power
 - adapter or cable may be faulty 192
 - battery may be partially charged 193
 - battery will not charge 192
 - light does not come on 192
 - AccuPoint II 194
 - computer emits a loud, high-pitched noise 205
 - computer will not start 180
 - data files are damaged or corrupted 198
 - disk drive
 - Non-system disk or disk error 181, 198
 - seems very slow 197
 - trouble accessing disk 197
 - disk or diskette drive
 - not accessed 180
 - diskette drive
 - cannot read diskette 198
 - diskette will not insert 198
 - DVD
 - playback performance is poor 199
 - DVDExpress
 - "Root" or "Title" menu does not open 200
 - controls are disabled 199
 - not functioning properly with "debug" software 201
 - performance decreases after a system change 200
 - slow playback performance 200
 - DVD-ROM drive 199
 - hot swapping fails 208
 - keyboard
 - AccuPoint II problems 194
 - error message(s) 194
 - locks and computer won't restart 194
 - nothing happens 194
 - nothing happens when pressing keys or AccuPoint II 180
 - unexpected characters 193
 - memory cards may be faulty 191
 - modem
 - will not receive or transmit properly 210
 - modem problems 210
 - no sound coming from the computer 205
 - PC Card
 - computer stops working when inserted 207
 - error occurs 208
 - slots don't work 207
 - system does not recognize 208

- PC Card checklist 206
- printer
 - will not print 209
 - will not print what's on the screen 209
- printer problems 209
- program does not run 198
- program performed illegal operation 178
- program stops responding 177
- screen display
 - blank 195
 - does not look right 196
 - external device does not work 196
 - problem with display settings 196
 - screen flickers 196
- sound system 205
- Windows 98 Second Edition
 - checking device properties 190
 - command prompt start-up 185
 - disabling a device 189
 - fails to start 181
 - Logged (BOOTLOG.TXT) 183
 - recording system start-up process 183
 - responds different from normal 181
 - screen display doesn't look right 181
 - start-up options 182
 - Step-by-step confirmation start-up 184
 - taking long time to start 181
- turning off the computer 54, 82

U

- Universal Resource Locator (URL) 137
- Universal Serial Bus (USB) 30
- USB port 227
- utilities
 - Toshiba Power Extensions 169
 - Toshiba's Power Saver 99

V

- video display device
 - connecting 122
- video modes 233
 - characteristics 233
- video port 29
- video/audio
 - playback 146
- Video-out port 226
- video-out port 29
- volume control dial 31

W

- warranty 54, 226
- Wi-Fi 31, 79, 226
- Windows 98 Second Edition
 - desktop 131
 - hardware conflicts 187
 - recording system's start-up process 183
 - Safe Mode 183
 - set up printer 119
 - taskbar
 - personalizing 137
 - troubleshooting assistance 186
- Windows Millennium Edition
 - Briefcase 137
- Wizards
 - Dial-Up Networking Wizard 79

Y

Y-cable 116